



greenlux
cost reduction LED lighting

Ecko 03 LED Gas Station Light Canopy Light

60W,80W,100W, 120W, 150W, 200W



- Nicely Design
- Easy to Install
- 150Lm/w
- 5 Years Warranty



60W, 80W, 100W, 120W, 150W, 200W

Beam Angle: 120°

Led Brand:  LUMILEDS

Brand Driver:  MEAN WELL

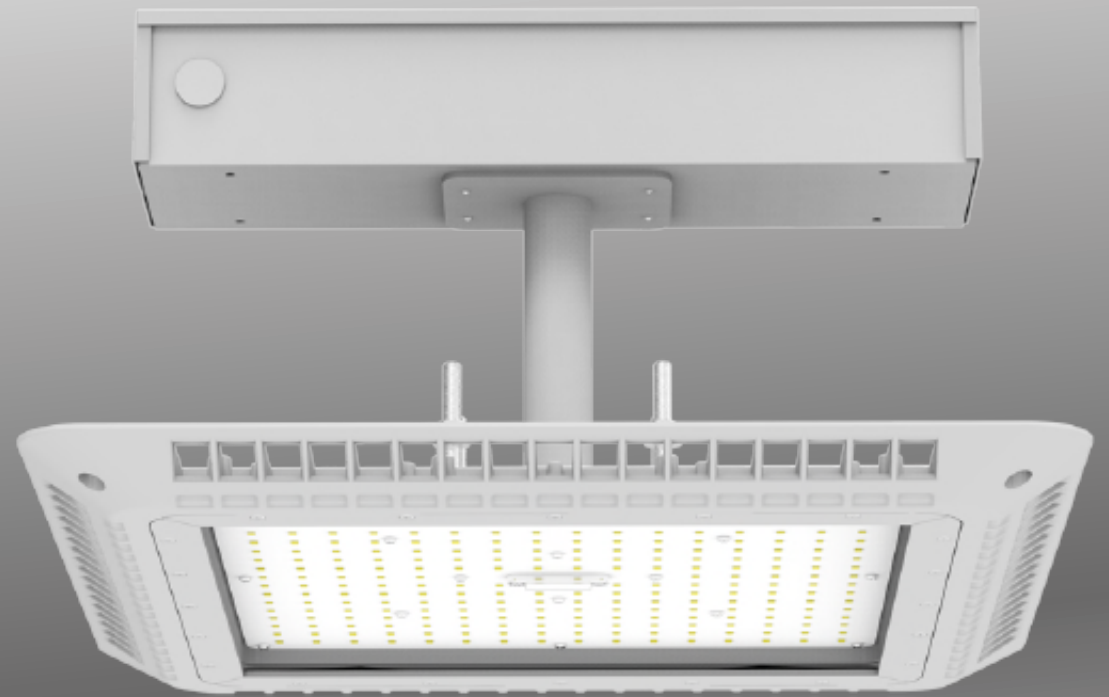
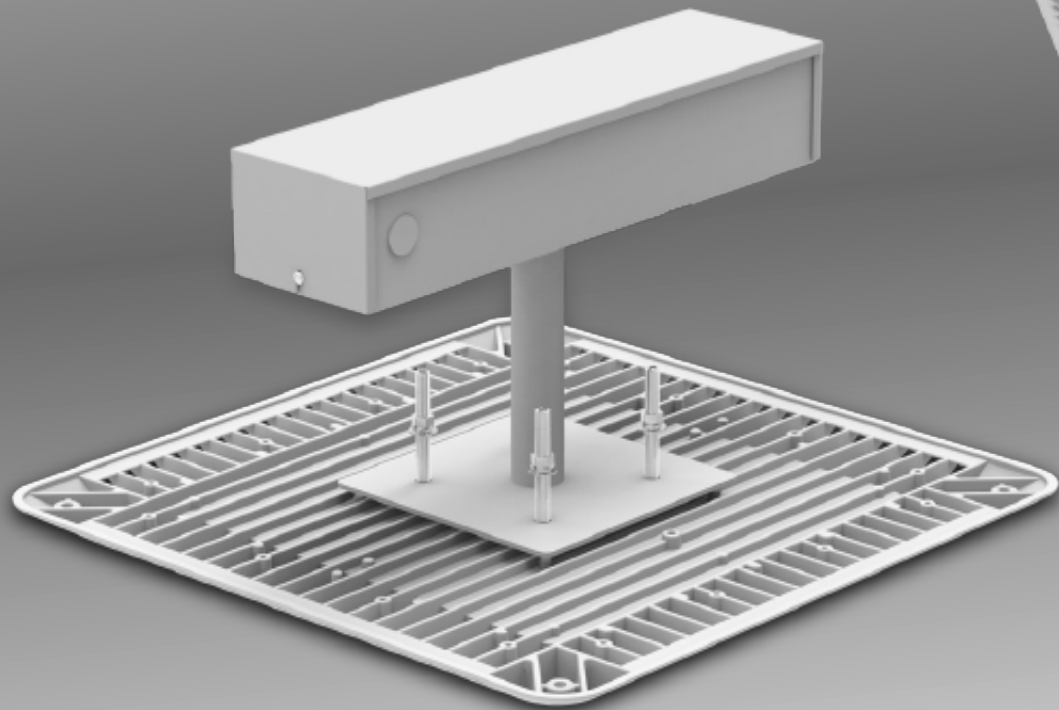

Hanging installation (Standard)

60W, 80W, 100W, 120W, 150W, 200W

Beam Angle: 120°

Led Brand:  LUMILEDS

Brand Driver: 

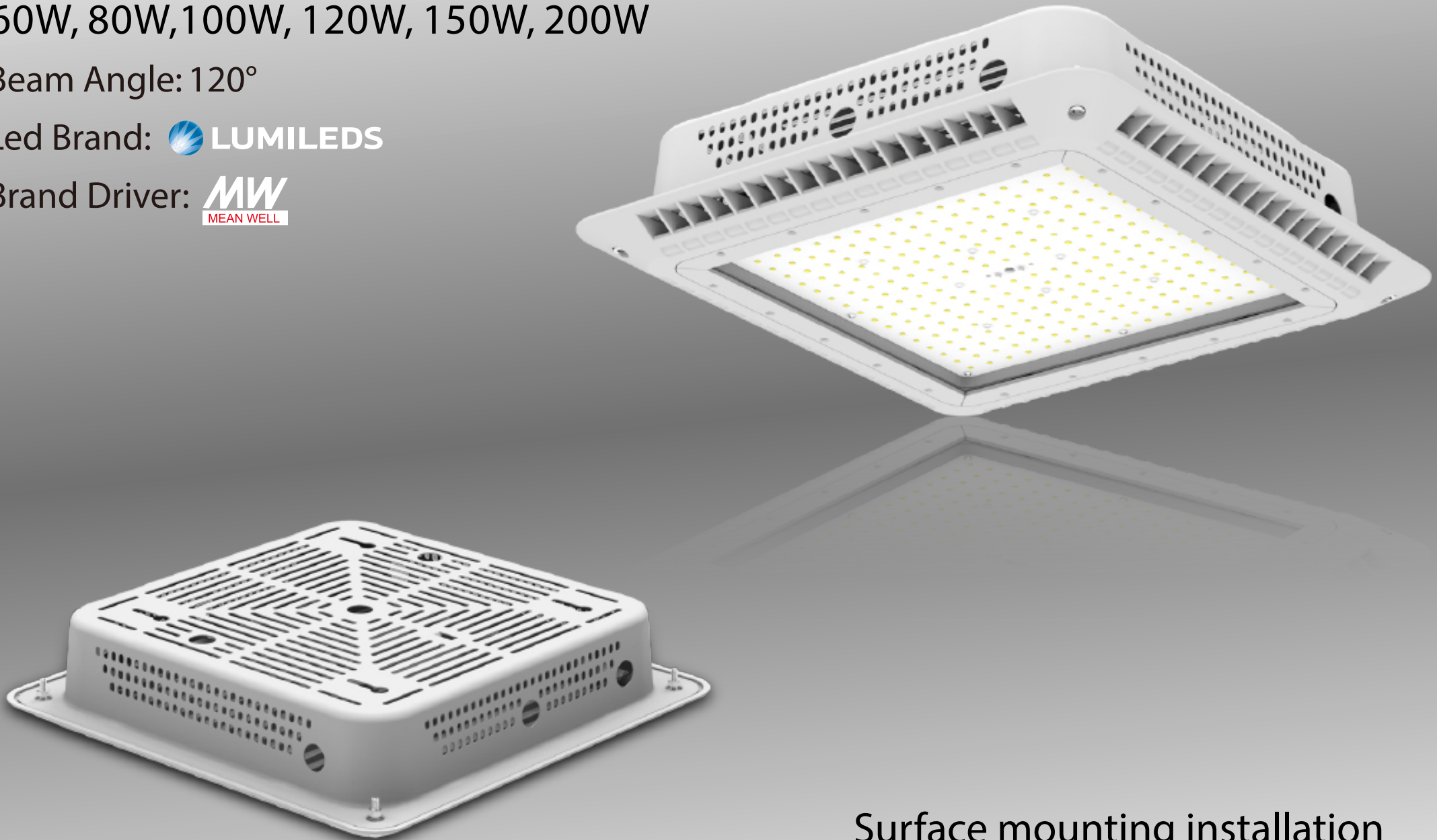

Surface mounting installation

60W, 80W, 100W, 120W, 150W, 200W

Beam Angle: 120°

Led Brand:  LUMILEDS

Brand Driver:  MW
MEAN WELL

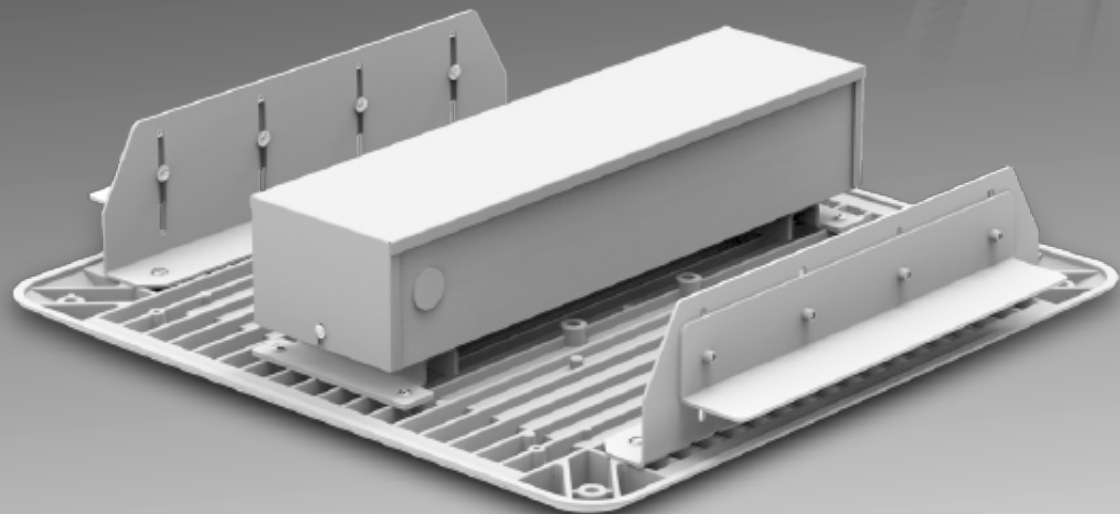
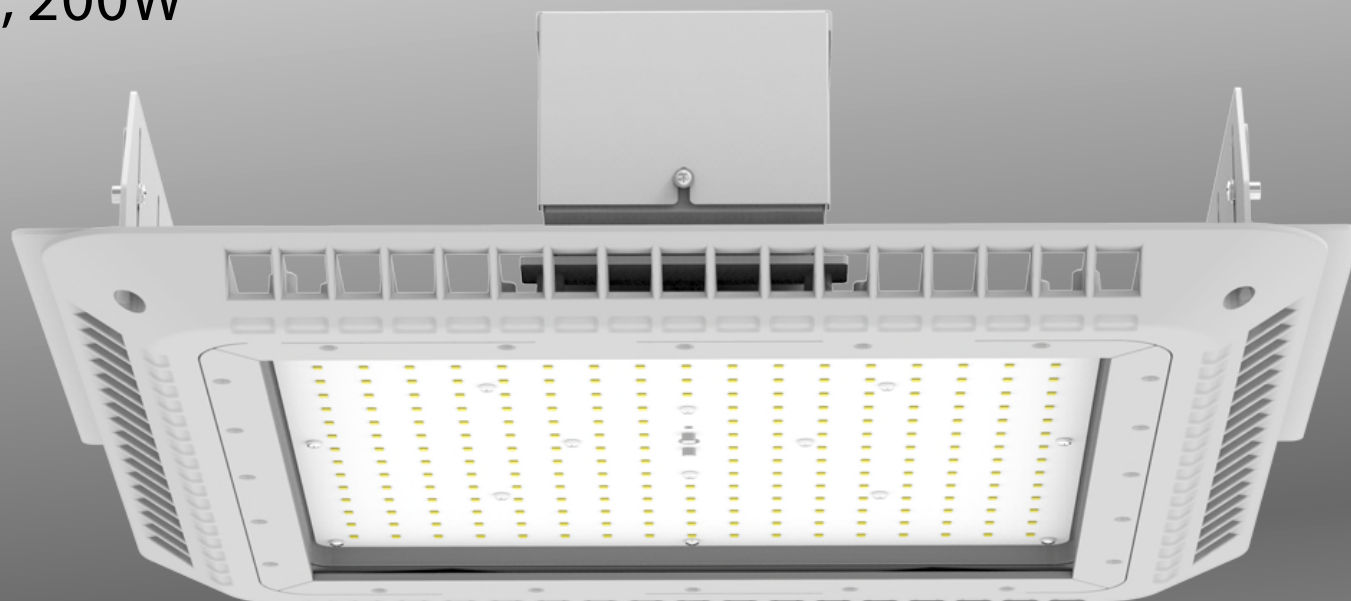

Recessed Installation Frame

1. Air convection design, for high heat conductivity and quickly heat dissipation.
2. Fine workmanship and elegant appearance. Easy to install.
3. Real IP65 waterproof. Great waterproof protection.

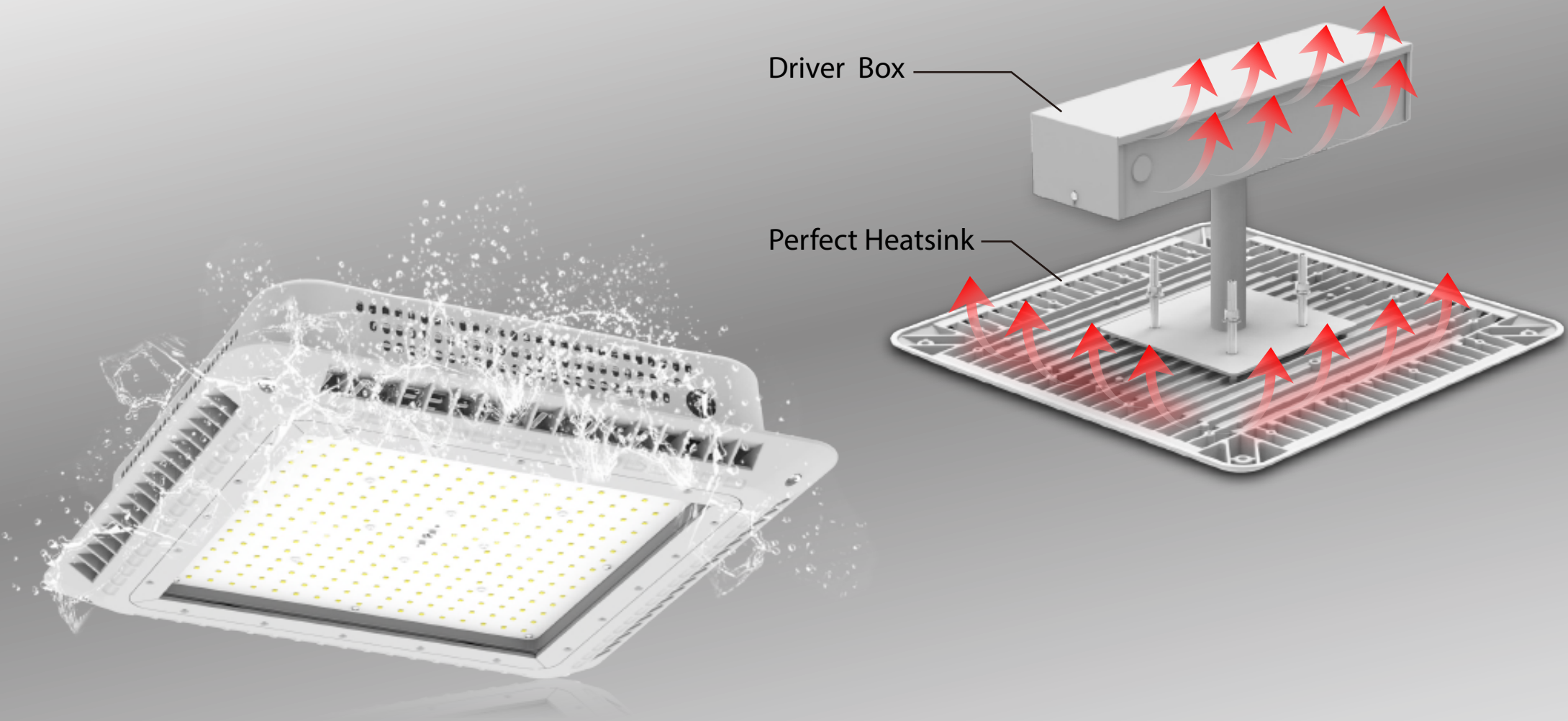

60W, 80W, 100W, 120W, 150W, 200W

Installation

60W, 80W, 100W, 120W, 150W, 200W

P1

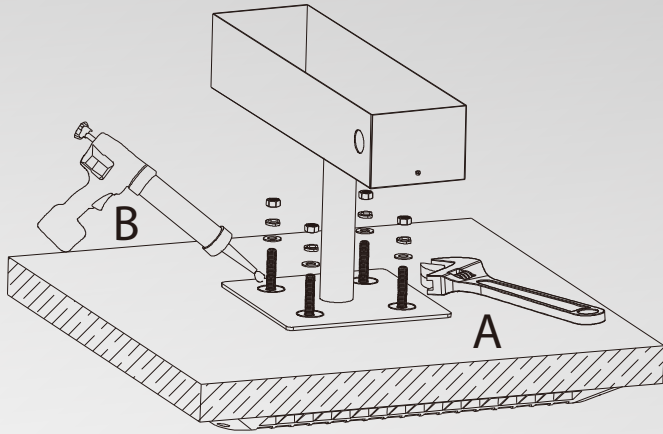

P2

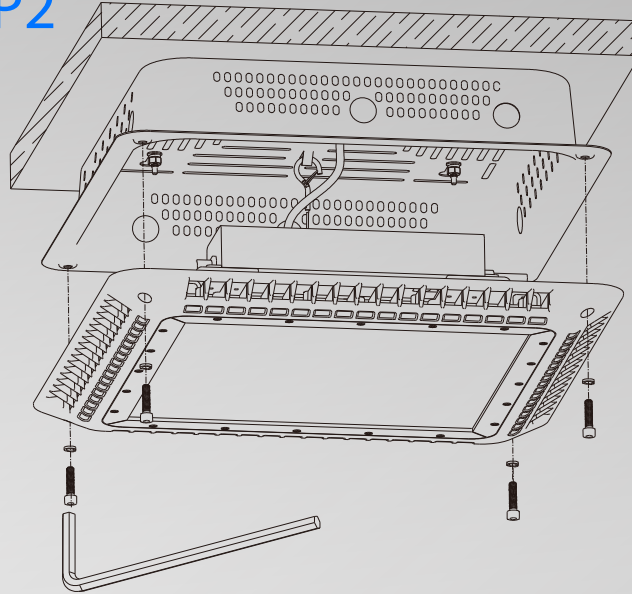

P3

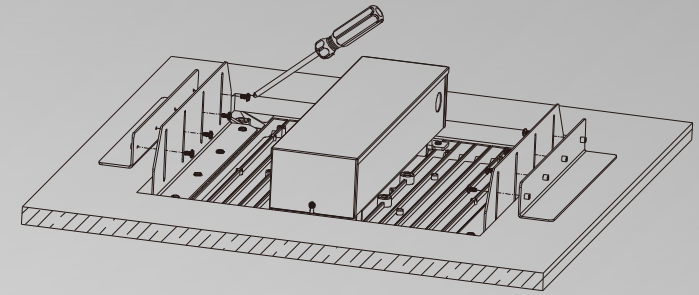

Hanging installation (Standard)



Surface mounting installation



Recessed Installation Frame