



greenlux
cost reduction LED lighting

Lunar **Small** LED Downlight IP65

Available in Multiple Wattage
80% lumen maintenance at 50,000 hours

- IP65 Wet area LED Downlight
- 90 beam angle
- No UV or IR rays. No mercury
- Replaces traditional recessed lights
- High quality Epistar chipset
- High lumen output
- High quality Aluminum housing
- Dimmable driver with AU Plug
- 3 Years Warranty
- Applications include shops, hotels, restaurants, offices, galleries, exhibiton buildings, particularly wet and damp environments

Specifications

Colour Range	3000-5000k
Luminous Flux	800 ~ 900lm
Power Consumption	10W
Input Voltage	AC 100V ~ 240V
Output Voltage	DC 30V
Current	300mA
Beam angle	90°
Ra	>85
Power Factor	>0.95
Chipset	Epistar
Driver	Class II
Dimmable	Triac / 0-10V / Dali (options)

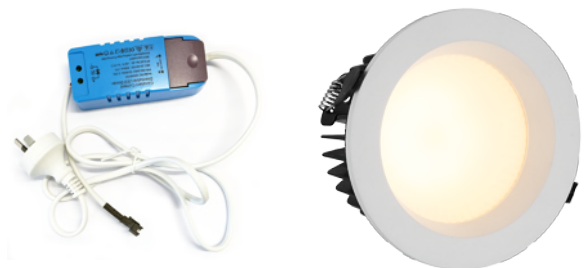

Dimmable Driver

Dimensions & Materials

Cutout	Ø90mm
Housing Material	Aluminum Alloy
Reflector	1090 Aluminum, polished anodizing & frosted diffuser
Housing Colour	Matte White Silver & Black (option)

IES

LM80

RCM

SAA

IP65

TUV

CE

3 Yrs
Warranty



greenlux
cost reduction LED lighting

Lunar **Small** LED Downlight IP65

Dimensions

Model: GDLUN-10W

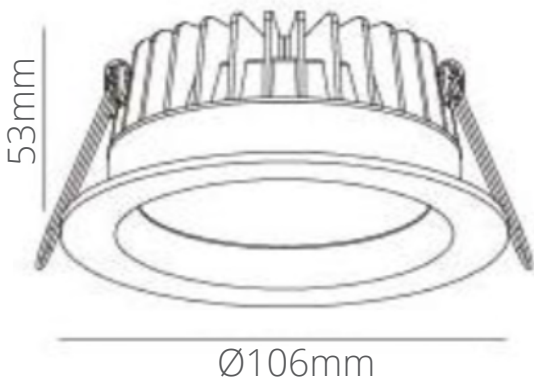

Photometric

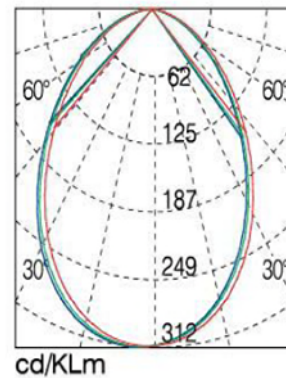

H(m)	E(lx)	D(m)
Beam Angle: 87.9°		
1 m	310.22 lx	1.93 m
2 m	77.56 lx	3.85 m
3 m	34.47 lx	5.78 m
4 m	19.39 lx	7.71 m
5 m	12.41 lx	9.63 m

Model

Model#	Dimensions (mm)	Cutout (mm)	Beam Angle	CCT	Lumens	Wattage	LED	Dimmer
GDLUN-10W	Ø106*53	Ø90	90°	3000k	850	10W	Epistar	Triac
GDLUN-10W	Ø106*53	Ø90	90°	4000k	900	10W	Epistar	Triac

Light CCT Guide

