



greenlux
cost reduction LED lighting

Eclipse Series 01 LED Wall Pack Light

Available in Multiple Wattage
80% lumen maintenance at 50,000 hours

- Energy saving as much as 90% compared with traditional lighting
- Die cast aluminum housing sealed with gasket
- Powder coated housing to prevent discoloration
- Shock & Vibration resistance
- High lumen output 110lm/W
- Easy installation bracket available
- Instant start, no noise, no flicker, anti-glare
- Class II SAA Driver
- Photocell sensor (option)
- Dark bronze, dirt-resistant
- IP65 Rated
- Applications include garages, commercial buildings, public area, schools and hospitals



Specifications

Colour Range	3000-6500k
Power Consumption	45W / 75W / 100W
Lumen	110lm/W
Input Voltage	AC 100~240V
Operating Temp.	-20°C to 50°C
Beam angle	110°
CRI	>80
Power Factor	>0.9
Chipset	SMD
IK Rating	IK08
Driver	Class II SAA

Dimensions (L*W*H)

Product Dimensions (mm)	360*235*190
Housing Material	Aluminium & Glass
Housing Color	Dark Bronze

Certification and Safety

Certifications	IP65, CE, RoHS, SAA, RCM
Environment	Outdoor & Indoor Location
Warranty	5 years





greenlux
cost reduction LED lighting

Eclipse Series 01 LED Wall Pack Light

Dimensions & Photometrics

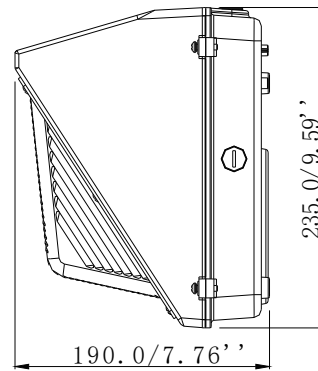
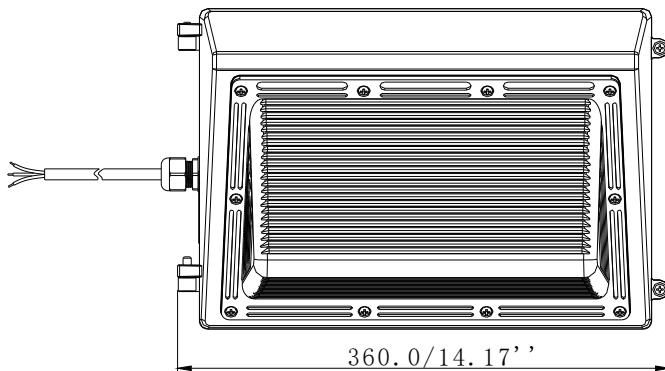

Product Range

Model#	Length (mm)	Beam Angle	CCT	Lumens	Wattage	LED
GMECL-45W-WP01	360*235*190	110°	3000-6500k	4600	45W	SMD
GMECL-70W-WP01	360*235*190	110°	3000-6500k	7600	70W	SMD
GMECL-100W-WP01	360*235*190	110°	3000-6500k	10500	100W	SMD

