

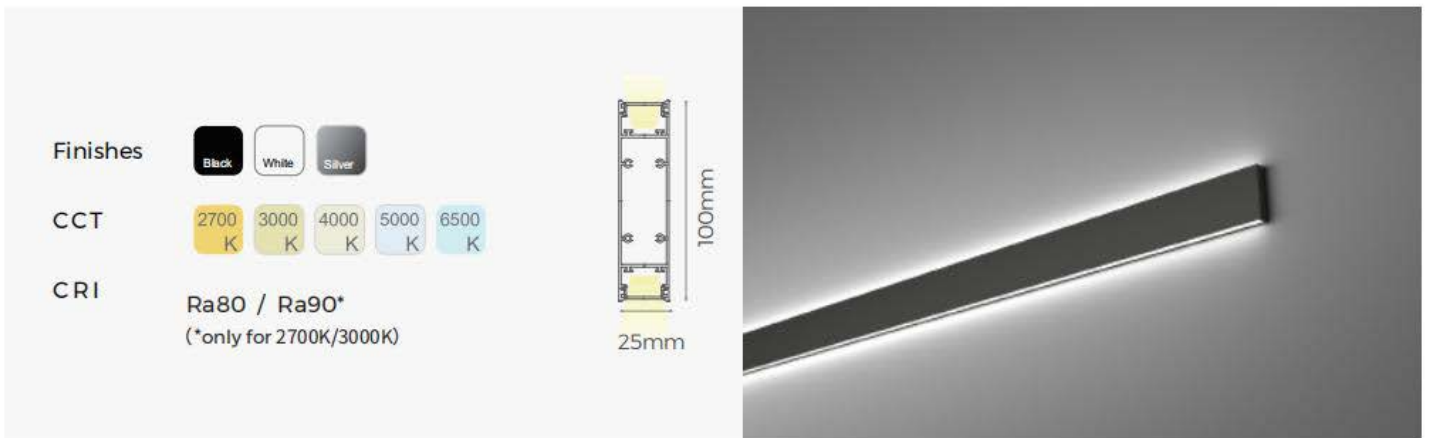

greenlux
cost reduction LED lighting



Chain GLC25 Wall Light



- Up / Down Lighting
- Wall Mounted
- 25mm Slim Lighting Surface
- High Efficiency 105lm/W, Lumen Output Up To 4200lm/m for Up / Down
- High Quality PC Diffuser, Uniform and Soft Light Output
- Buid-in Power, Invisible Design

Chain GLC25 Wall Light

Model	Size	Length	Diffuser
GCCHA-GLC25-27W	25 * 100mm	600mm	27W / 2266LM
GCCHA-GLC25-52W	25 * 100mm	1200mm	52W / 4532LM
GCCHA-GLC25-65W	25 * 100mm	1500mm	65W / 5665LM
GCCHA-GLC25-80W	25 * 100mm	1800mm	80W / 7040LM
GCCHA-GLC25-100W	25 * 100mm	2400mm	100W / 9064LM

1.2m Luminaire with Diffuser

Remark:

1. The tolerance of output data can be vary up to 10%
2. The output data is a typical value

