

TL38 Series LED Track Light



LM80

5 Yrs
Warranty



SAA

IP20

TUV

9/331 Ingles Street
Port Melbourne VIC 3207 Australia

info@greenlux.com.au
sales@greenlux.com.au

T 1300 650 625
www.greenlux.com.au



Introduction

The LED track light with simple and elegant design, one track light with adjustable beam angle varies from 15° to 60°, creating a diversified and dramatic atmosphere. Lens optical design with even light output. Changeable lighting orientation with 350° in horizontal direction and 90° in vertical direction. Aluminum heat sink provides excellent heat dissipation.

Features

- Supreme Aluminum heat sink with great heat dissipation.
- Citizen brand LED, CRI80/90/97 optional.
- Adjustable beam angle from 15° to 60° .
- 1-circuit and 3-circuit adapters for options.
- Adjustable lighting orientation with 350° in horizontal direction and 90° in vertical direction.

Application Areas

It is suitable for supermarket, specialty store, show window, exhibition hall; focus lighting, decorative and background lighting, where attention is focused on subjects to emphasise special visual points.



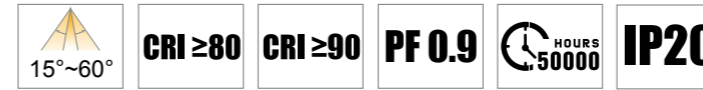

Technical Data Sheet

Model No.	GUTL38-10W-D	GUTL38-25W-D	GUTL38-30W-D	GUTL38-15W	GUTL38-25W	GUTL38-30W		
Dimension(mm)	Ø65*234	Ø80*260	Ø100*265	Ø65*234	Ø80*260	Ø100*265		
Cutout (mm)	-							
Watt(W)	10W	25W	30W	15W	25W	30W		
Rated Input Voltage(V)	AC230V							
Input Voltage(V)	AC220-240V							
LED Module Input	-							
Light Source	COB							
SDCM	-							
CCT(K)	1-CCT: 2700K/3000K/4000K/5000K							
CCT Selection DIP Switch	No							
Luminous Flux (lm) ±5%	Non-DIM	1-CCT	-			500~1500	750~2500	1000~3000
			DIM	330-960	700-2500	950-2800	-	
	Non-DIM	3-CCT	-					
			DIM	-				
CRI	Ra>80 (Ra>90 Ra>97 optional)							
Beam Angle (°)	15° ~ 60°							
UGR	-							
LED Driver	Built-in							
Dimming Option	Triac							
Sensor	-							
Emergency Kits	-							
Electrical Class	Class I							
Ingress Protection (IP Rating)	IP20							
Impact Resistance (IK Rating)	-							
Product Finishing(Base)	White RAL 9016 / Black RAL9005							
Materials of Optics	PC							
Materials of Housing	Aluminum							
Lifetime (hr)	50,000h							
Glow wire test (°C)	850°C							
Operating Temp. (°C)	-20°C ~45°C							
Storage Temp. (°C)	-20°C ~65°C							
Installation	Track							

Measurement

Model	Dimension(mm)				Size(mm)	Product Weight (Kg)	
	A	B	C	D		N.W/PC	G.W/PC
GUTL38-10W-D	234	65	137	84.5	Ø65*234	0.69	0.82
GUTL38-15W	234	65	137	84.5	Ø65*234	0.69	0.82
GUTL38-25W-D	260	80	163	84.5	Ø80*260	0.91	1.07
GUTL38-25W	260	80	163	84.5	Ø80*260	0.91	1.07
GUTL38-30W-D	265	100	173	84.5	Ø100*265	1.29	1.5
GUTL38-30W	265	100	173	84.5	Ø100*265	1.29	1.5

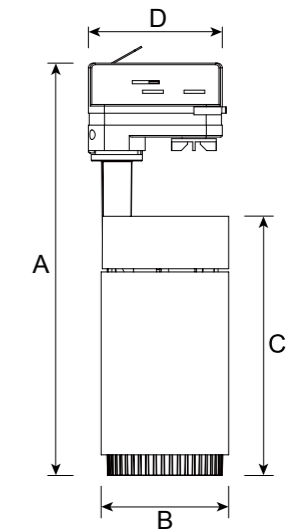

Driver Datasheet (Non-Dimmable)

Total load wattage		15W±1W	25W±5%	30W±5%
Output	Output Voltage range	DC30-40V		
	Rated output current	350mA	600mA	750mA
	Line Regulation	±5%		
	Setup, Rise Time	<0.5S		
	Flickering Index	-		
Input	Input Voltage	-		
	Rated Input Voltage(V)	AC200-240V		
	Frequency	50/60Hz		
	Input Current	0.09A	0.15A	0.18A
	Rated Input Current	-		
	Power Factor	0.9		
	THD	≤20%(230V)		
	Efficiency	84%	86%	
	No load wattage	-		
	Protection	Short circuit protection	Pass	
Over voltage protection		Pass		
Over temperature protection		Pass		
Safety & EMC	Withstand voltage	AC1500V		
	Isolation Resistance	I/P-O/P: 500VDC, ≥100M Ω		
	Surge	L-N 500V,L,N-PG 1KV	L-N 1KV,L,N-PG 2KV	
	EMC Emission	EN55015, EN61000-3-2		
EMC Immunity	EN61000-4-2,3,4,5,6,8,11; EN61547			

Driver Datasheet (Triac Dimmable)

Total load wattage		10W	25W	30W
Output	Output Voltage range	DC30-40V		
	Rated output current	220mA	580mA	700mA
	Line Regulation	±5%		
	Setup, Rise Time	<1s		
	Flickering Index	<10%		
Input	Input Voltage	AC200-240V		
	Rated Input Voltage(V)	AC230V		
	Frequency	50Hz		
	Input Current	0.06A	0.14A	0.17A
	Rated Input Current	0.05A	0.13A	0.15A
	Power Factor	0.9		
	THD	--	<20%	
	Efficiency	78%	84%	85%
	No load wattage	<1W		
	Protection	Short circuit protection	Pass	
Over voltage protection		Pass		
Over temperature protection		Pass		
Safety &EMC	Withstand voltage	I/P-O/P:3.75kVac, <5mA 60S; I/P-FG:1.6kVac, <5mA 60S; O/P-FG:0.5kVac, <5mA 60S		
	Isolation Resistance	I/P-O/P: 500VDC, ≥100M Ω		
	Surge	IEC/EN61000-4-5(L-N:0.5KV, L/N-PG:1KV)	IEC/EN61000-4-5(L-N:1KV, L/N-PG:2KV)	
	EMC Emission	IEC/EN55015, IEC/ EN61000-3-2		
	EMC Immunity	IEC/EN61000-4-2,3,4,5,6,8,11; IEC/EN61547		

Installation Procedure

WARNING ⚡

1. Switch off power supply before installation / maintenance.
2. Switch on after completing installation and examination of the circuit.
3. The track light must be installed and maintained by professional electrician.

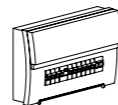

Installation Guide

Step 1

Before locating Adaptor into Track Section, make sure it is set in the 'OFF' position & 'Locking Lever' is set in the position as shown below.

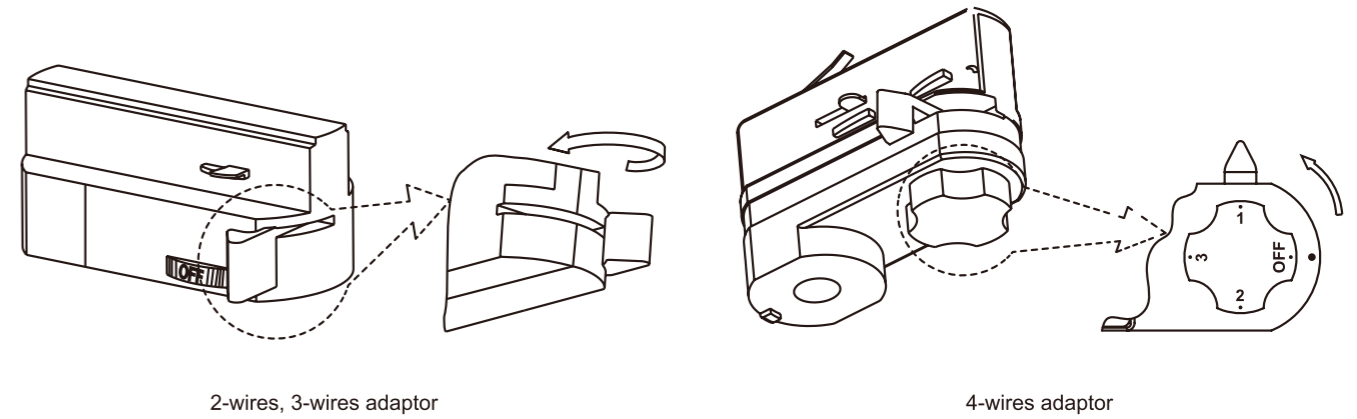

Step 2

Locate Track Adaptor into Track Section (1) & lock into position by turning 'Locking Lever' 90°(2)

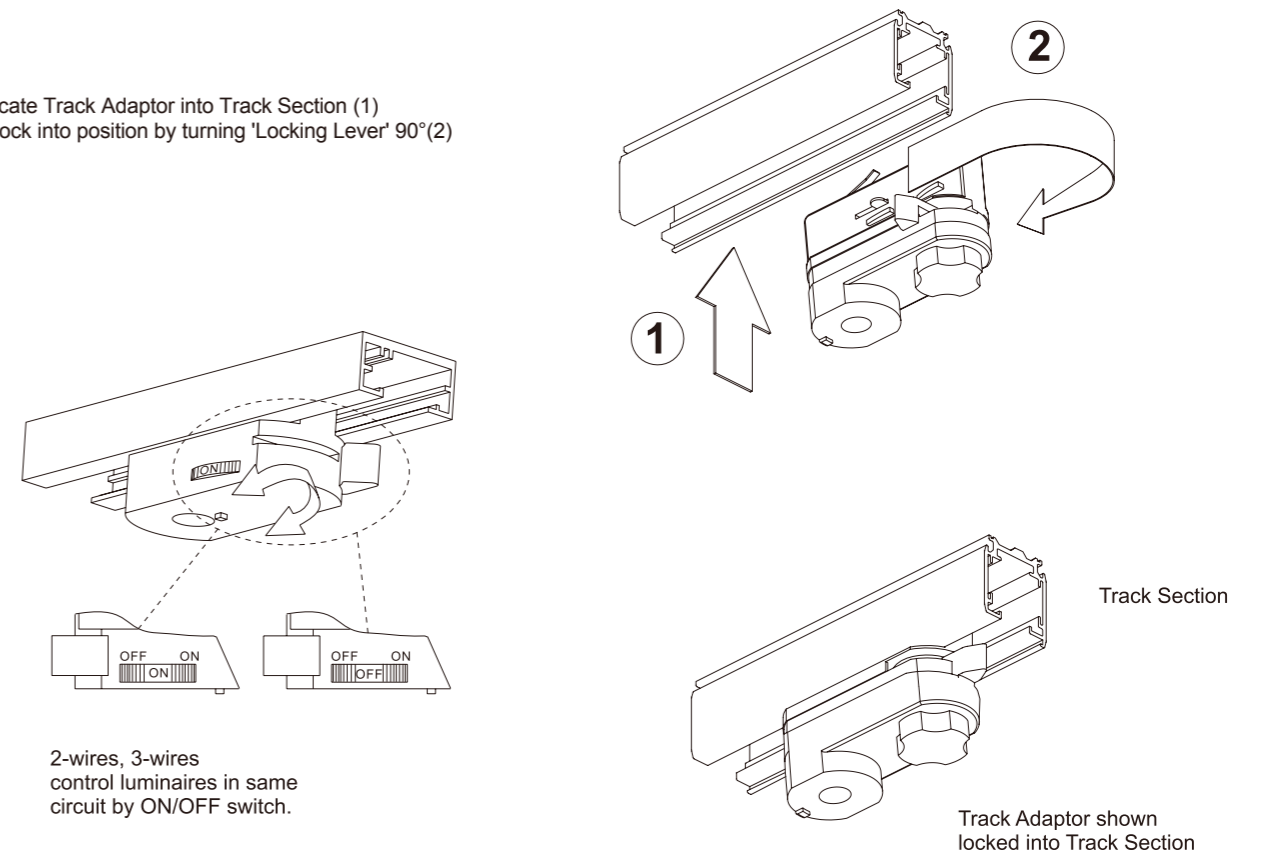

2-wires, 3-wires control luminaires in same circuit by ON/OFF switch.

4-wires Turn clockwise or anti-clockwise.

