

Opal BL Series

Backlit LED Panel Light 110lm/W UGR<19

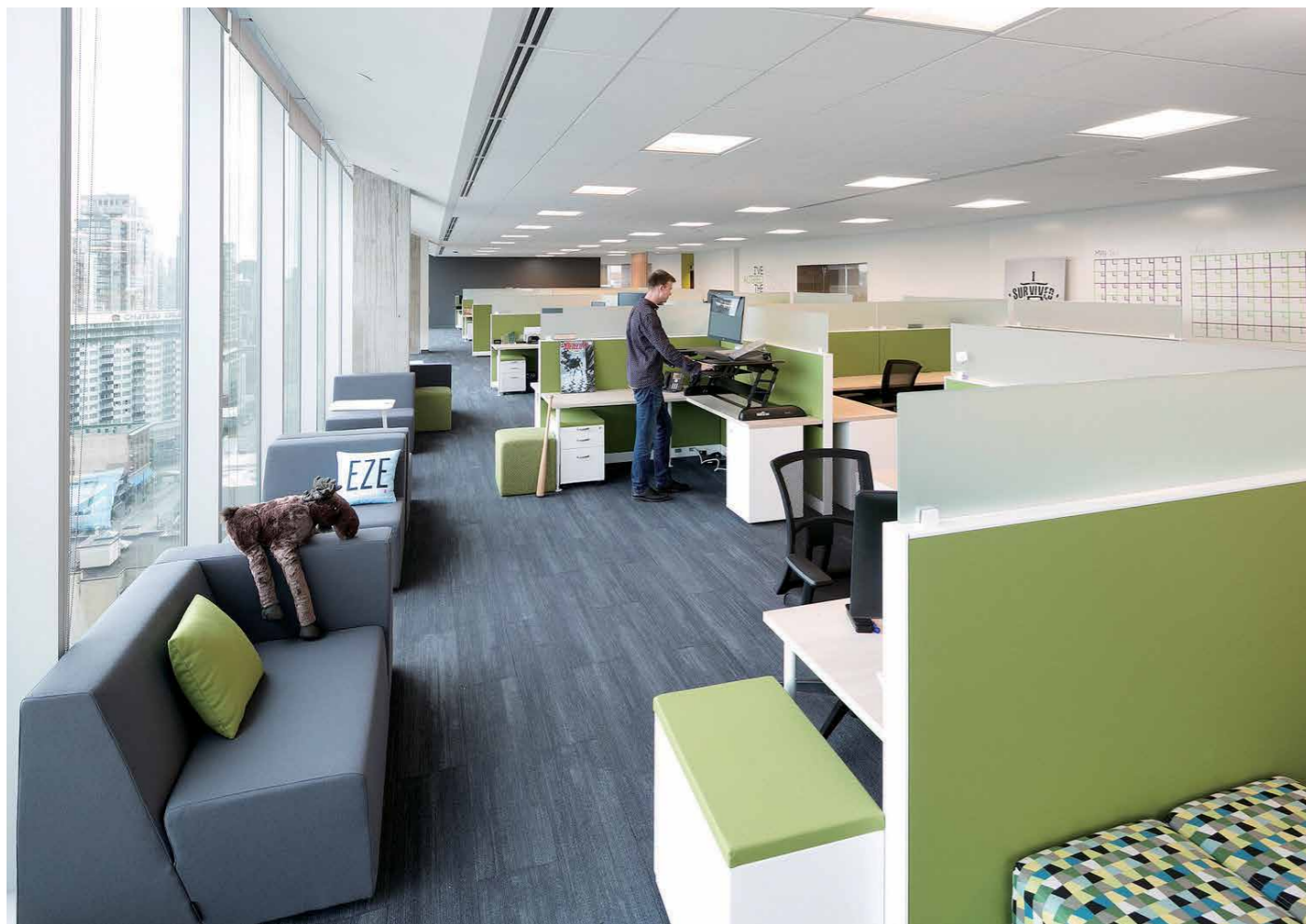



Introduction

Backlit LED Panel Light is a direct lighting product with high lumen efficiency. It makes full use of all light and is more cost effective compared with side lighting LED panel light. Adopt optical lens to offer a uniform light effect. With integrated iron plate, it provides great thermal management.

Features

- Uniform light effect with optic lens.
- Integrated iron plate design provides excellent thermal management.
- Concise design offers high cost performance.
- Built-out driver.
- Installation: recessed, suspended and surface mounted.

Application Areas

Office & school lighting: office room, meeting room, class room etc. Commercial lighting: shopping mall, super market, retailer shops etc. Other situations: hospital, laboratory, dust-free workshop etc.

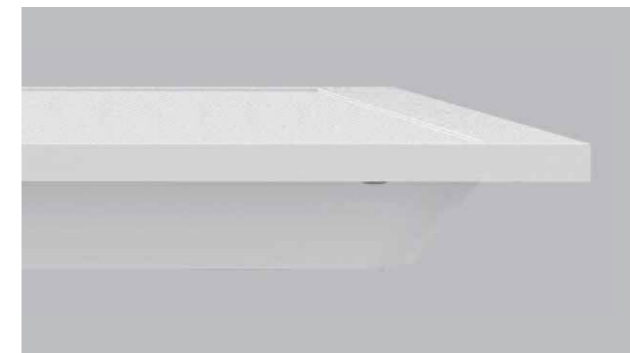
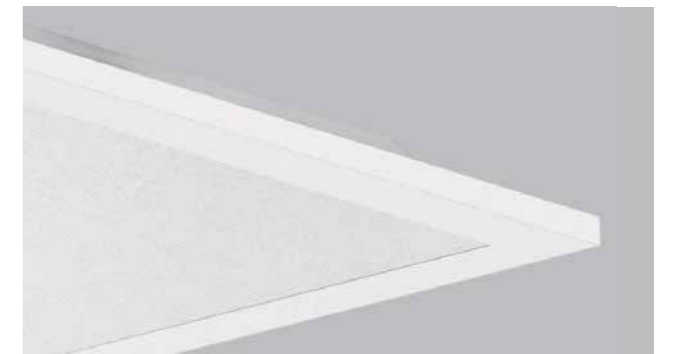
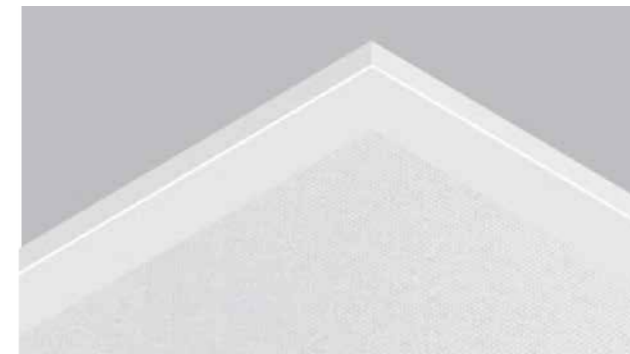
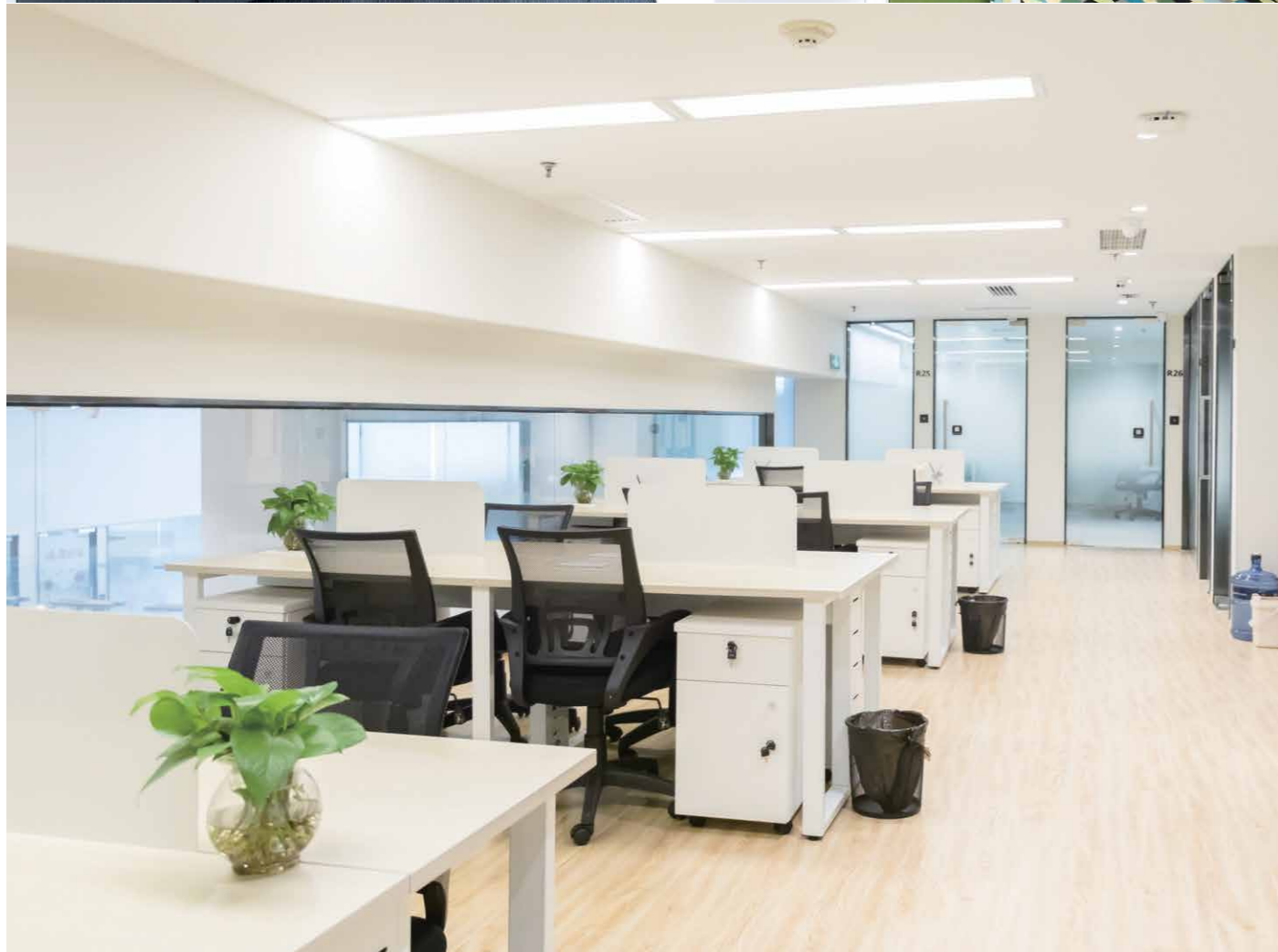

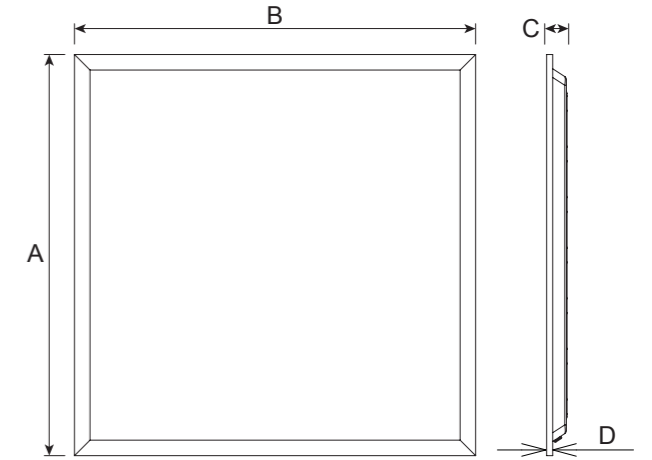
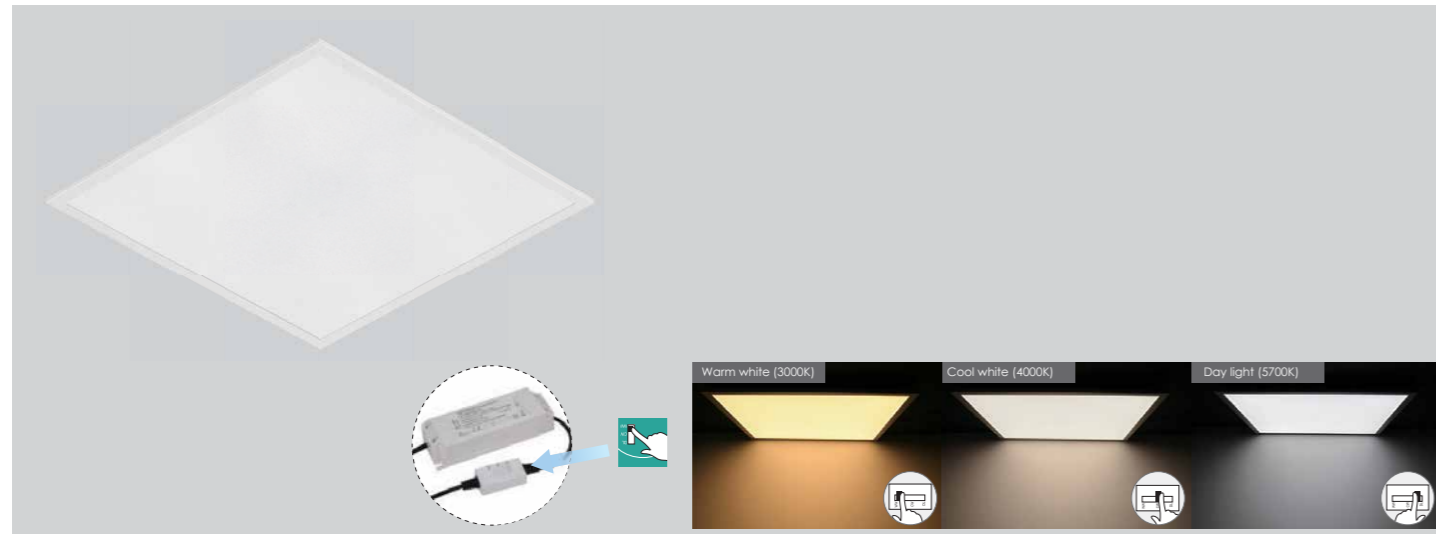

Technical Data Sheet

Model No.	GUOPA-16W-3060-BL-110	GUOPA-30W-6060-BL-110	GUOPA-30W-6262-BL-110	GUOPA-30W-1230-BL-110	GUOPA-36W-6060-BL-110	GUOPA-36W-6262-BL-110	GUOPA-36W-1230-BL-110	GUOPA-50W-1260-BL-110	GUOPA-60W-1260-BL-110		
Dimension(mm)	295*595*32	595*595*32	620*620*32	295*1195*32	595*595*32	620*620*32	295*1195*32	595*1195*32	595*1195*32		
Cutout (mm)	-										
Watt(W)	16W	30W	30W	30W	36W	36W	36W	50W	60W		
Rated Input Voltage(V)	AC230										
Input Voltage(V)	AC200-240V										
LED Module Input	30-42V DC 400mA CC	30-42V DC 750mA CC	30-42V DC 750mA CC	30-42V DC 750mA CC	30-42V DC 900mA CC	30-42V DC 900mA CC	30-42V DC 900mA CC	30-42V DC 1300mA CC	30-42V DC 1500mA CC		
Light Source	SMD										
SDCM	-										
CCT(K)	1-CCT: 3000K/4000K/5000K/5700K 3-CCT: 3000K+4000K+5700K										
CCT Selection DIP Switch	Yes										
Luminous Flux (lm) ±5%	Non-DIM	1-CCT	1760-1920	3300-3600	3300-3600	3300-3600	3960-4320	3960-4320	3960-4320	5500-6000	6600-7200
			DIM	1670-1820	3130-3420	3130-3420	3130-3420	3760-4100	3760-4100	3760-4100	5220-5700
	Non-DIM	3-CCT	1720-1880	3230-3520	3230-3520	3230-3520	3880-4230	3880-4230	3880-4230	5390-5880	6470-7050
			DIM	1630-1790	3070-3340	3070-3340	3070-3340	3680-4020	3680-4020	3680-4020	5120-5580
CRI	≥80 (≥90 Optional)										
Beam Angle (°)	90°										
UGR	<19										
LED Driver	Built-out										
Dimming Option	Triac / 0-10V / DALI										
Sensor	-										
Emergency Kits	-										
Electrical Class	Class II										
Ingress Protection (IP Rating)	IP40										
Impact Resistance (IK Rating)	-										
Product Finishing(Base)	White 9016										
Materials of Optics	PMMA(Lens)+PS(Diffuser)										
Materials of Housing	Aluminum(Frame)										
Lifetime (hr)	50,000h										
Glow wire test (°C)	650°C										
Operating Temp. (°C)	-20°C ~45°C										
Storage Temp. (°C)	-20°C ~65°C										
Installation	Pendant/recessed/Surface mounted.										

Measurement

Model	Dimension(mm)				Size(mm)	Product Weight (Kg)	
	A	B	C	D		N.W/PC	G.W/PC
3060	295	595	32	9	295*595*32	1.01	1.25 2.37
6060	595	595	32	9	595*595*32	1.56	1.97 3.67
6262	620	620	32	9	620*620*32	1.98	2.44 4.55
1230	295	1195	32	9	295*1195*32	1.72	2.16 4.02
1260	595	1195	32	9	595*1195*32	3.2	3.95 7.4

Driver Datasheet (Non-Dimmable)

Total load wattage		16W	30W	36W	50W	60W
Output	Output Voltage range	DC30-42V				
	Rated output current	400mA	750mA	900mA	1300mA	1500mA
	Line Regulation	±5%				
	Setup, Rise Time	≤1S				
Input	Flickering Index	-				
	Input Voltage	AC200-240V				
	Rated Input Voltage(V)	AC230V				
	Frequency	50/60Hz				
	Input Current	≤0.09A	≤0.17A	≤0.2A	≤0.28A	≤0.34A
	Rated Input Current	≤0.08A	≤0.15A	≤0.18A	≤0.25A	≤0.29A
	Power Factor	≥0.9				
	THD	<20% @230V				
	Efficiency	≥85%	≥88%	≥88%	≥88%	≥88%
	No load wattage	<0.5W				
Protection	Short circuit protection	Pass				
	Over voltage protection	Pass				
	Over temperature protection	Pass				
Safety & EMC	Withstand voltage	AC3750V				
	Isolation Resistance	I/P-O/P: 500VDC, ≥100M Ω				
	Surge	L-N 0.5KV	L-N 1KV	L-N 1KV	L-N 1KV	L-N 1KV
	EMC Emission	EN55015, EN61000-3-2, FCC PART 15				
EMC Immunity	EN61000-4-2,3,4,5,6,8,11; EN61547, FCC PART 15					

Driver Datasheet (Triac Dimmable)

Total load wattage		16W	30W	36W	50W	60W
Output	Output Voltage range	DC30-42V				
	Rated output current	400mA	750mA	900mA	1300mA	1500mA
	Line Regulation	±5%				
	Setup, Rise Time	≤1S				
	Flickering Index	-				
Input	Input Voltage	AC200-240V				
	Rated Input Voltage(V)	AC230V				
	Frequency	50/60Hz				
	Input Current	≤0.09A	≤0.17A	≤0.2A	≤0.28A	≤0.34A
	Rated Input Current	≤0.08A	≤0.15A	≤0.18A	≤0.25A	≤0.29A
	Power Factor	≥0.9				
	THD	<20% @230V				
	Efficiency	≥82%	≥85%	≥85%	≥85%	≥85%
	No load wattage	<1W				
	Protection	Short circuit protection	Pass			
Over voltage protection		Pass				
Over temperature protection		Pass				
Safety &EMC	Withstand voltage	AC3750V				
	Isolation Resistance	I/P-O/P: 500VDC, ≥100M Ω				
	Surge	L-N 0.5KV	L-N 1KV	L-N 1KV	L-N 1KV	L-N 1KV
	EMC Emission	EN55015, EN61000-3-2, FCC PART 15				
	EMC Immunity	EN61000-4-2,3,4,5,6,8,11; EN61547, FCC PART 15				

Installation Procedure

WARNING ⚡

1. Switch off power supply before installation / maintenance.
2. Switch on after completing installation and examination of the circuit.
3. The panel light must be installed and maintained by professional electrician.

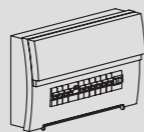

Turn Off Power Supply

Turn off power supply before installation. Read instructions and make sure you have all the tools and accessories before installation.

Recessed into ceiling

Step 1

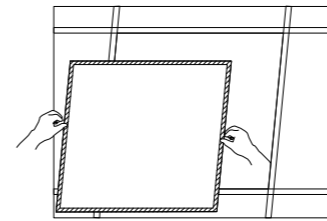

Remove the ceiling plaster slab.

Step 2

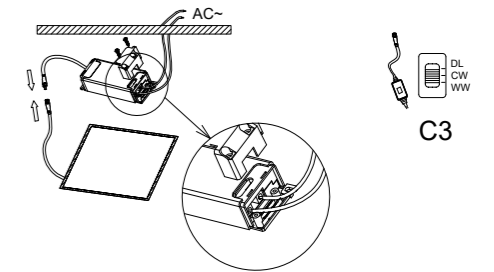

Fix 2pcs of clips to one side of frame by screw, then insert the frame into ceiling.

Step 3

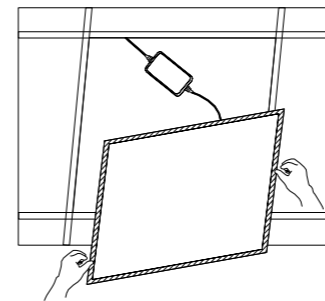

Fix the panel light into plaster ceiling.

Step 4

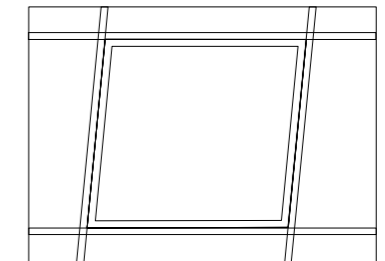

Make sure the led panel light is firmly fixed, turn on the power.

Suspending

Step 1

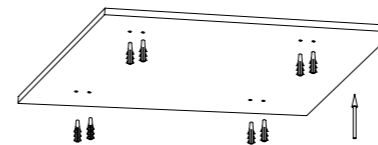

Fix the anchor into target place on the ceiling.

Step 2

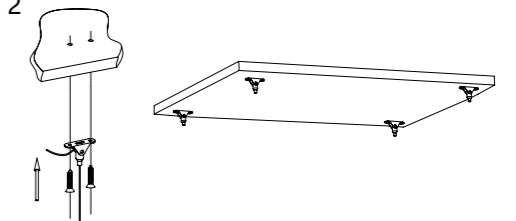

Fix the installation mount on the ceiling with plastic anchor.

Step 3

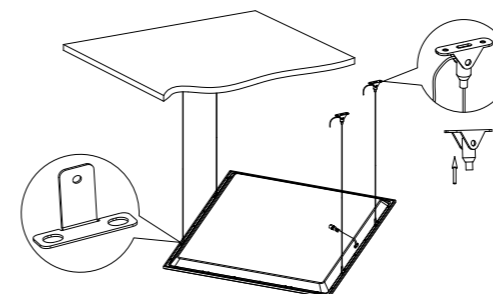

Hang the panel to ceiling with suspended installation kits, adjust the length of steeling wires.

Step 4

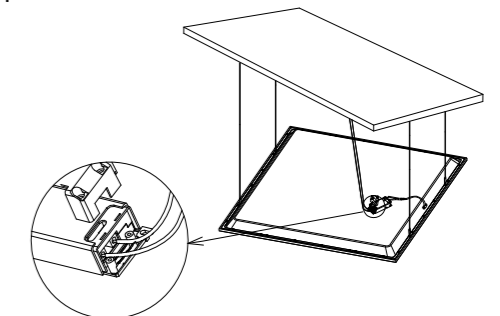

Feed the main AC wire in driver terminal block respectively, turn on the power.

Step 1

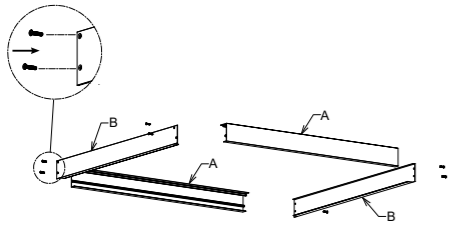

Assemble the surface mounted frame and fix by screws.

Step 2

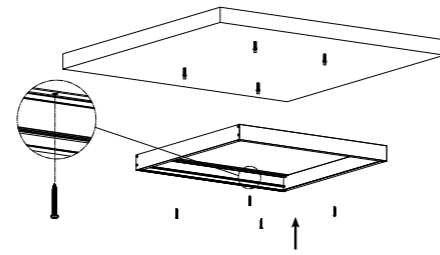

knock the plastic anchor into ceiling, fix the surface mounted frame on the ceiling by screws.

Step 3

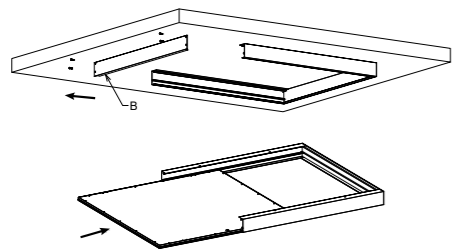

Unscrew the side frame then take out, connect the panel light to power supply, insert the panel light into the frame.

Step 4

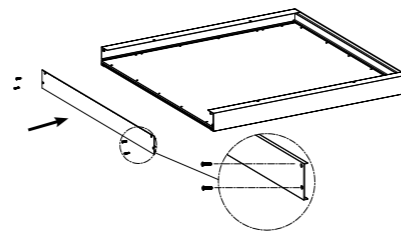

Fix the side frame back by screw.

Step 5

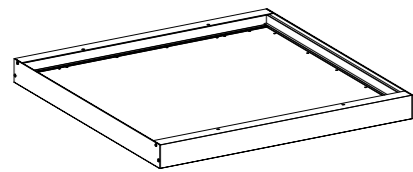

Make sure the frame and panel light are firmly fixed, turn on the power.