

## **Circus Series 01**

LED Dimmable Pendant Light  
( Surface Mounted )



## Description

- Surface Mounted.
- 120° wide beam angle.
- Simple, elegant design.

## Finish

Black / White

## Material

Aluminium Housing

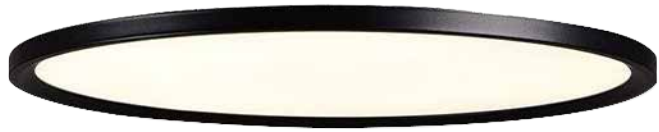

SAA

IES

TUV



RoHS

LM80

IP40

## Specification

<b>Installation</b>	Surface Mounted
<b>Colour Range</b>	3000 ~ 5000k
<b>Chipset</b>	SMD
<b>Power Consumption</b>	18W ~ 80W
<b>Lumen</b>	95lm/W
<b>Input Voltage</b>	100 ~240V AC
<b>Beam Angle</b>	120°
<b>CRI</b>	>80 / >90
<b>Power Factor</b>	>0.9
<b>Dimmable</b>	Triac Dimmer
<b>Warranty</b>	5 Years

<b>Product Dimension (mm)</b>	Ø300 * 12
	Ø400 * 12
	Ø500 * 12
	Ø600 * 12
	Ø780 * 20

## Dimensions

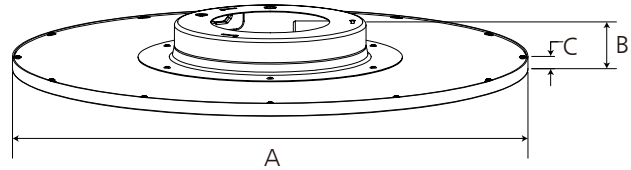
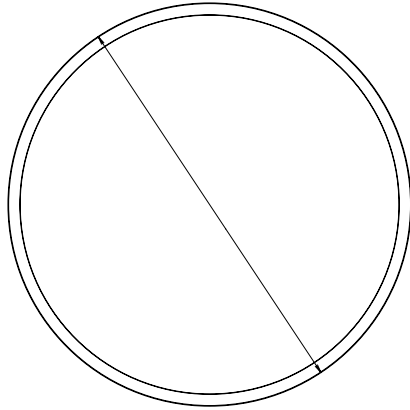

Model	Dimensions (mm)			Power	Power Factor	Lumen (±5%)	Beam Angle	CCT	CRI	Dimmable
	A	B	C							
GUCIR-18W-3012-01	300	55	12	18W	≥0.9	1560	120°	3000K ~ 5700K	≥80 / 90	Yes / No
GUCIR-25W-4012-01	400	55	12	25W	≥0.9	2170	120°	3000K ~ 5700K	≥80 / 90	Yes / No
GUCIR-35W-4012-01	400	55	12	35W	≥0.9	3080	120°	3000K ~ 5700K	≥80 / 90	Yes / No
GUCIR-30W-5012-01	500	55	12	30W	≥0.9	2460	120°	3000K ~ 5700K	≥80 / 90	Yes / No
GUCIR-35W-5012-01	500	55	12	35W	≥0.9	2900	120°	3000K ~ 5700K	≥80 / 90	Yes / No
GUCIR-35W-6012-01	600	55	12	35W	≥0.9	3040	120°	3000K ~ 5700K	≥80 / 90	Yes / No
GUCIR-45W-6012-01	600	55	12	45W	≥0.9	3600	120°	3000K ~ 5700K	≥80 / 90	Yes / No
GUCIR-60W-7820-W	780	73	20	60W	≥0.9	5070~5430	120°	3000K ~ 5700K	≥80 / 90	Yes / No
GUCIR-80W-7820-W	780	73	20	80W	≥0.9	6825~7460	120°	3000K ~ 5700K	≥80 / 90	Yes / No

# Installation Procedure

## WARNING

1. Switch off power supply before installation / maintenance.
2. Switch on after completing installation and examination of the circuit.
3. The pendant light must be installed and maintained by professional electrician.



**Turn Off  
Power Supply**

Turn off power supply before installation. Read instructions and make sure you have all the tools and accessories before installation.

## Installation Instructions - Surface Mounted

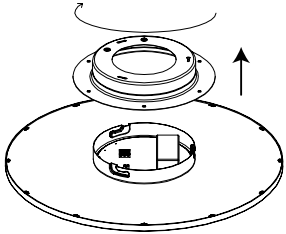
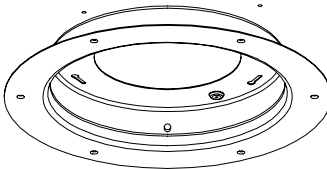
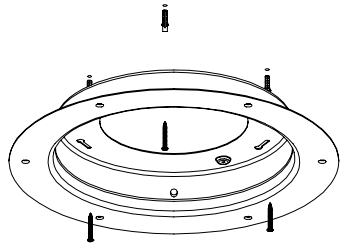
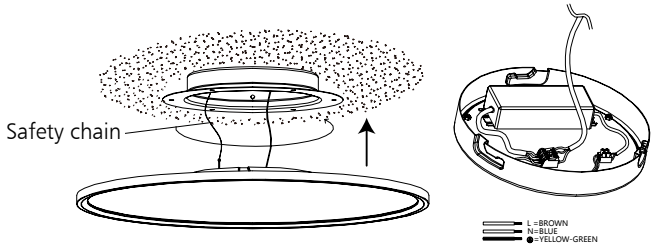
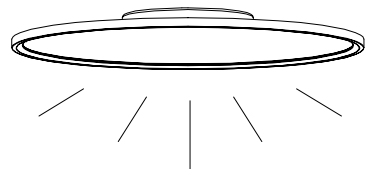
 <p>1. Unpack the lamp and accessory pack from the box, rotate the installation bracket and take it out.</p>	 <p>2. Drill the screw holes in needed mounting location.</p>	 <p>3. Knock-in the plastic anchor into ceiling. Fix bracket into the ceiling using screw.</p>
 <p>4. Hold the lamp and knock the safety rope, feed the AC wire, then fix the lamp tightly by rotating it.</p> <p><small>— L = BROWN — N = BLUE ● = YELLOW-GREEN</small></p>	 <p>5. Switch on power, installation completed.</p>	