

Car Parking Step Dimming 12V Motion Sensor

1. Features

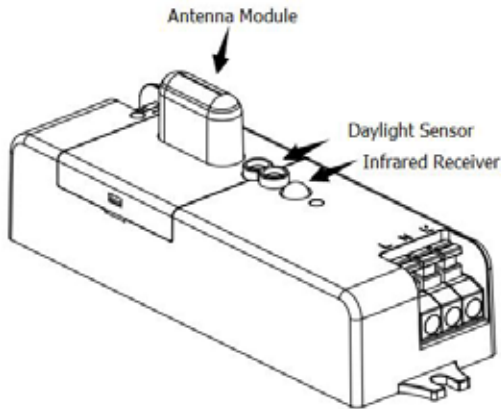

- Newly designed patent needle, overcome the shortage of traditional needle antenna, no blind detection area
- Stable performance when mount in metal roof warehouse
- Slim cut-hole size, fit for tri-proof light, batten, troffer
- All parameters can be set by remote control
- Override function
- 5 years warranty

2. Parameter

Input	Operating Voltage	108-305V AC 50/60Hz
	Rated Voltage	120/277V AC 50/60Hz
	Stand-by Power	≤1W
	Surge Test	L→N: 1kV
Output	Working Mode	ON/OFF function, 1-10V step dimming
	Type of Load	Inductive or resistive Load
	Load Capacity	2A @120Vac ,3A@277Vac, 3A@220-240Vac
	Max. Surge Capacity	30A (50%Ipeak,twidth =500uS, 230Vac full load, cold start); 60A (50% Ipeak,twidth=200uS, 230Vac, full load, cold start)
Dim Interface	1-10V Dimming	1-10Vdimming
Sensor Parameters	Operating Frequency	5.8 GHz ±75 MHz, ISM Band.
	Transmitting power	0.5mW Max.
	Hold time	5s/30s/1min/3min/5min/10min/20min/30min
	Stand-by DIM Level	10%(1.4-1.6V), 20%(1.9-2.1V), 30%(2.9-3.1V) , 50% (4.9-5.1V)
	Stand-by Period	0s/10s/1min/3min/5min/10min/30min/+∞
	Detection Area	100%/75%/50%/25%
	Daylight Sensor	5lux/15lux/30lux/50lux/100lux/150lux/Disable
	Detecting Radius	≥4m(mount height 3m, moving speed 0.3m/s)
	Mounting Height	6m Max
	Detecting Angle	150°
Operating	Operating Temperature	-25℃...+60℃

Environment	Storage Temperature	Temperature:-40°C...+80°C; Humidity:10%-95% (non-condensing)
Certificate Standards	Safety standards	EN61058-1, UL60703-1
	EMC standards	EN300440; EN301489-1; EN55015; EN61547; EN61000-3-2; EN61000-3-3; EN62479
	Environmental Requirement	Compliant to RoHS
	Certificate	CE
Others	Input/output terminal specifications	Push-type terminal block; wire diameter: 0.75-1.5mm ²
	IP Rating	IP20
	Protection Class	Class II
	Installation	Built-in installation
	Dimension	See dimension
	Package	Bubble bag + partition + outer box (K=A)
	Net Weight	61.2G
	Lifetime	5 years warranty@Ta 230V full load
<p>Note</p> <p>1. "N/A" means not available.</p> <p>2. Detection area is effected on volume of motion object and motion speed. The detection area is tested by a 165cm height person and walking speed is 0.3m/s.</p>		

3. Function

1) On/OFF Function (stand-by period be set to "0"s)

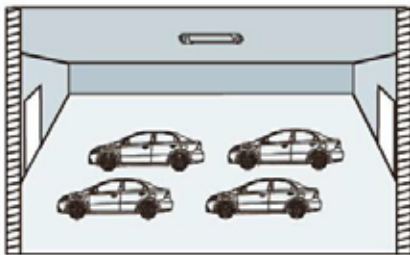

1 With sufficient ambient light, the light will not be switched on even if with motion signal.

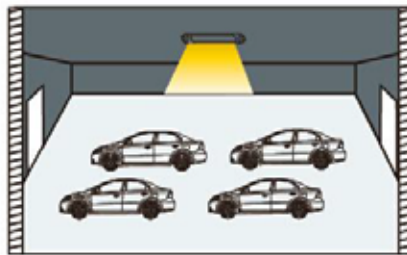

2 With insufficient ambient light, the sensor switches on the light when motion is detected.



3 After elapse of hold time, the sensor switches off the light when no motion is detected.

2) 2-step dimming function (stand-by period be set to "+∞")

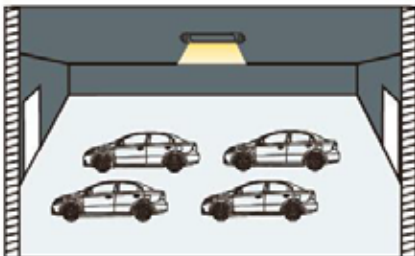

1 If there is no motion detected, the light will be remained at a low light level all the time.

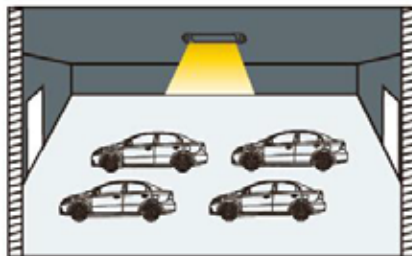

2 When motion is detected, the sensor will switch on the light to 100% brightness

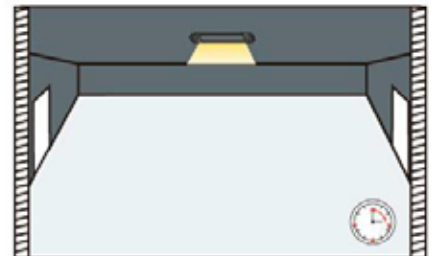

3 After elapse of hold time, the sensor dims the light at the present low light level if no motion is detected.

3) 3-step dimming function (stand-by period be set to "10s/1min/3min/5min/10min/30min")

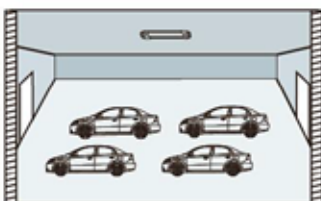

1 With sufficient ambient light, the light will not be switched on even if with motion signal.

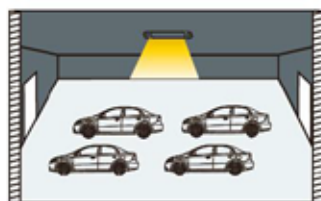

2 With insufficient ambient light, the sensor switches on the light when motion is detected.

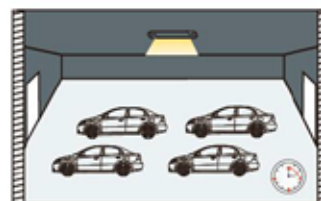

3 After elapse of hold time, the sensor dims the light at a low light level if no new motion is detected.



4 After elapse of standby period, the sensor switches off the light if no motion is detected in the detection zone.

4. Dimension (mm)

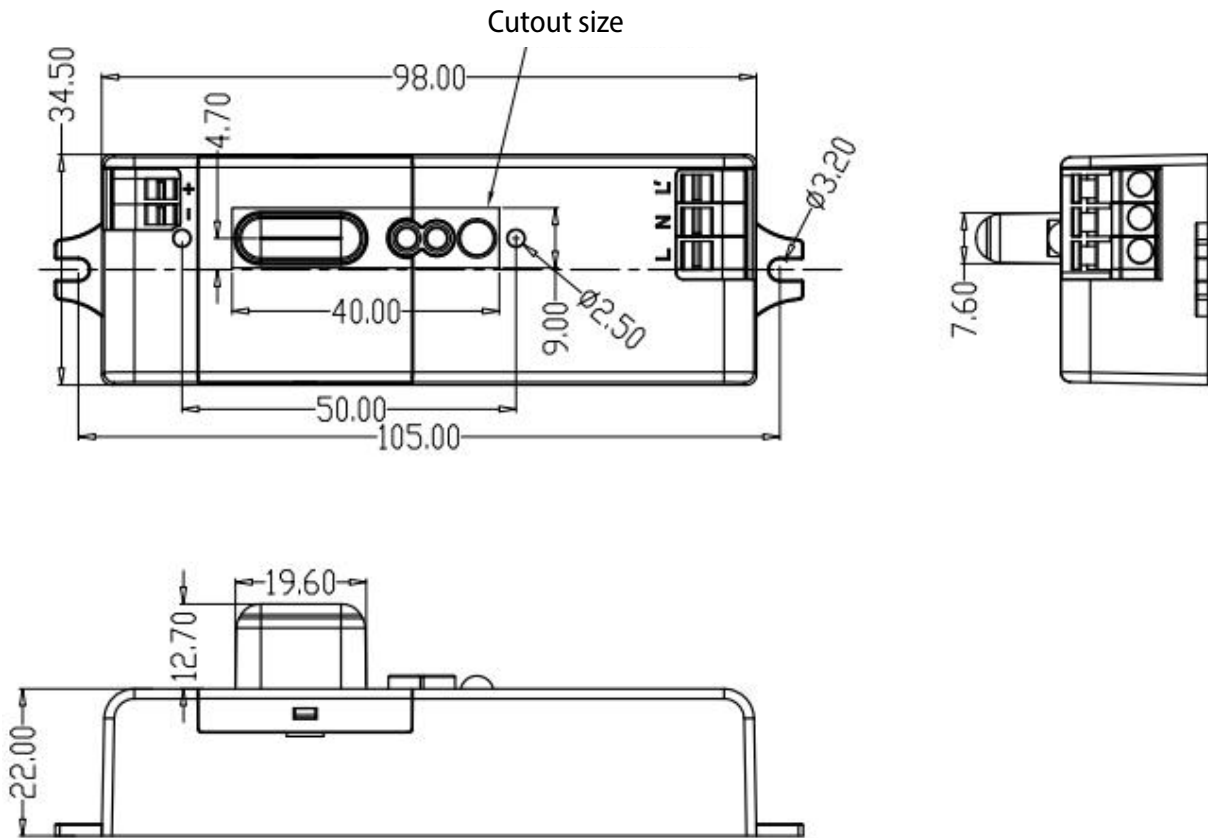

5. Wiring

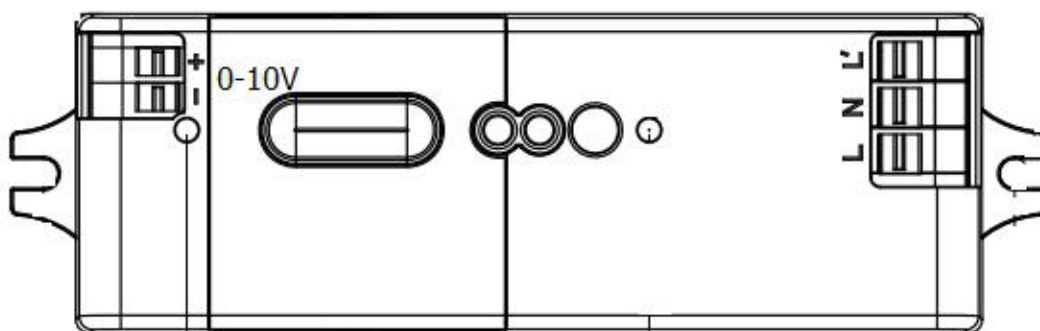

*The sensor is designed for connect one load only. Connect more than one loads may damage the sensor.

6. Function Diagram

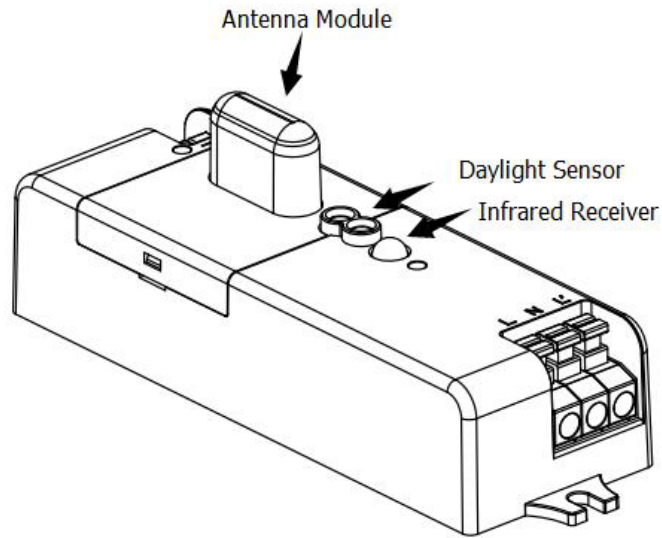

7. Installation directive

- 1) Sensor antenna must be out of LED plate

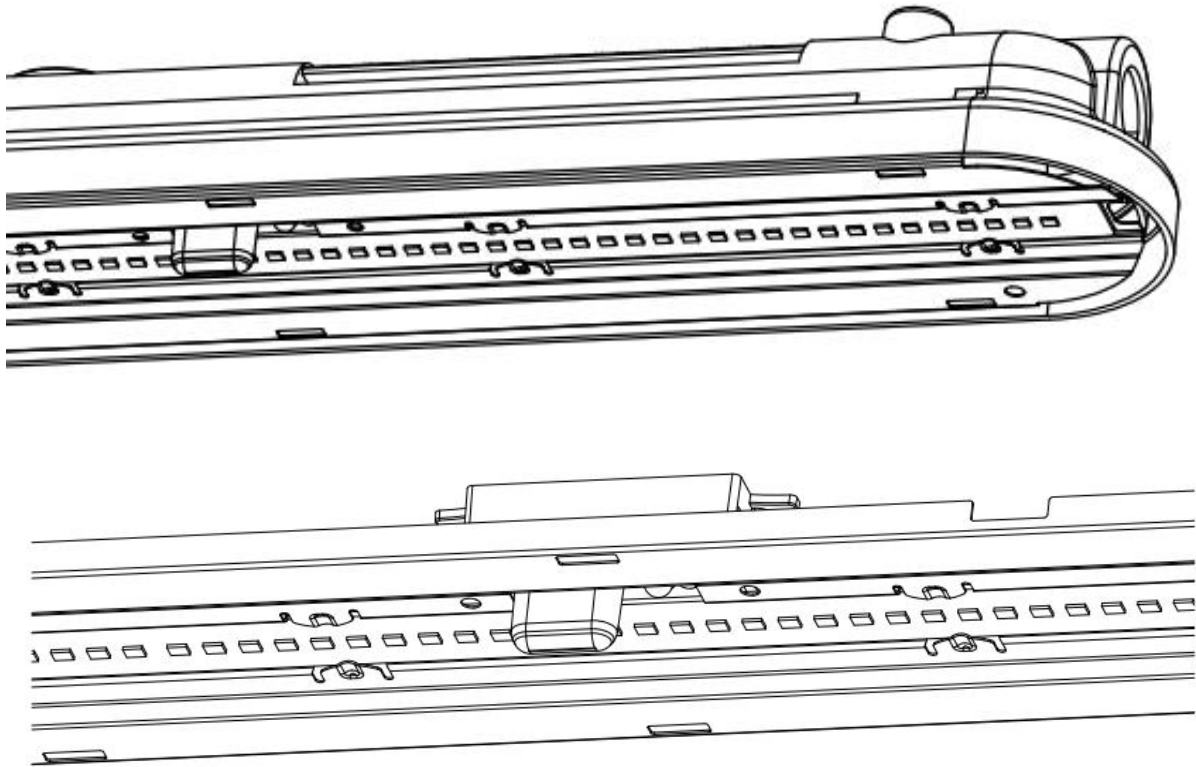

8. Radiation Pattern

1) Ceiling mounting

Mounting height: 3m

Detection area: 100%/75%/50%/25%

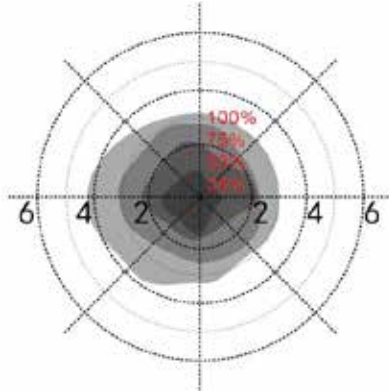

Mounting height: 6m

Detection area: 100%/75%

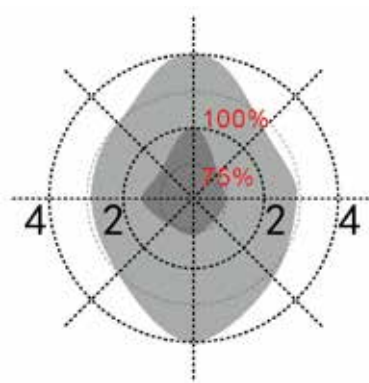

Moving speed: 0.3m/s

Moving speed: 0.3m/s)

*When mount 6m in height, sensor can detect motion sensor @100%/75%

2) Wall mounting

Mounting height 1.2m

Detection area: 100%

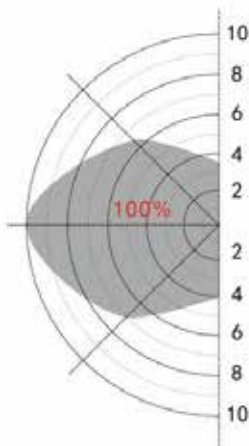

Moving speed 0.3m/s

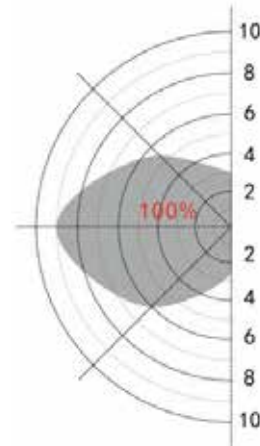

Moving speed: 0.3m/s

9. Remote Control

Remote Control Setting	Button	Remarks																												
		Press the "ON/OFF" button, the light goes to constant on/off mode, sensor is disabled, Press "Reset" "Auto mode" button to quit from this mode and the sensor starts to work.																												
	Reset	Press "Reset" button, all parameters are same as setting of DIP switch or factory settings.																												
	Sensor motion	Press "Sensor motion" button, the light quits from the constant on/off mode, and the sensor starts to work (The latest setting stays in validity)																												
	DIM Test	Press "DIM Test" button, the 1-10 V dimming works to test whether the 1-10Vdc dimming ports are connected properly. After 2s, it returns to the latest setting automatically.																												
	Dverride DH	Long press 3s, Daylight priority mode will be switched to daylight threshold mode, lux value will go back to previous one.																												
	DIM+ DIM-	Short press "DIM+/DIM-" button to Set the output lumen level, each press will will $\pm 2\%$ light level																												
	DH Mode	Long press >3s, sensor will be switched to daylight priority mode; if preset daylight value is Disable, press DH Mode can not start daylight priority mode.																												
	Q1 Q2 Q3	<table border="1"> <thead> <tr> <th>Scene Options</th> <th>Detection Area</th> <th>Hold Time</th> <th>Stand-by period</th> <th>Stand-by dim level</th> <th>Daylight Sensor</th> <th>Induction model</th> </tr> </thead> <tbody> <tr> <td>QS1</td> <td>100%</td> <td>5min</td> <td>10min</td> <td>10%</td> <td>30Lux</td> <td>Hs</td> </tr> <tr> <td>QS2</td> <td>100%</td> <td>10min</td> <td>30min</td> <td>10%</td> <td>Disable</td> <td>Hs</td> </tr> <tr> <td>QS3</td> <td>100%</td> <td>20min</td> <td>30min</td> <td>10%</td> <td>Disable</td> <td>Hs</td> </tr> </tbody> </table>	Scene Options	Detection Area	Hold Time	Stand-by period	Stand-by dim level	Daylight Sensor	Induction model	QS1	100%	5min	10min	10%	30Lux	Hs	QS2	100%	10min	30min	10%	Disable	Hs	QS3	100%	20min	30min	10%	Disable	Hs
Scene Options	Detection Area	Hold Time	Stand-by period	Stand-by dim level	Daylight Sensor	Induction model																								
QS1	100%	5min	10min	10%	30Lux	Hs																								
QS2	100%	10min	30min	10%	Disable	Hs																								
QS3	100%	20min	30min	10%	Disable	Hs																								
	TEST 2S	Press the "TEST 2S" button can enter the test mode any time. At the mode, the sensor parameters as below: Detection Area is 100%, Hold Time is 5s, Stand-by Dim Level is 10%, Stand-by Period is 0s, daylight sensor disable. This function only for testing. Quit the mode by pressing "RESET" or any other function buttons.																												
	HS LS	Press "HS" button to set the detection area to be high sensitive. Press "LS" button to set the detection area to be low sensitive. The adjustment bases on the "Detection Area" parameter you set.																												
	Daylight Sensor	Set up daylight threshold: 5Lux/15Lux/30Lux/50Lux/100Lux/150Lux/ Disable.																												
	Stand-by period	Set up stand-by time: 0S/10S/1min/3min/5min/10min/30min/+∞																												
	Hold time	Set up hold time: 5S/30S/1min/3min/5min/10min/20min/30min																												
	Stand-by dim level	Set up stand-by dim level: 10%/20%/30%/50%																												
	Detection Area	Set up detection area: 25%/50%/75%/100%																												
	Remote Distance	Toggle button can set the remote distance of remote control and sensor.																												

10. Initialization

1/ On/Off function /3-step dimming function:

After power on, the sensor automatically turns on light at 100% brightness. After 10sec, it turns off the light. During

the initialization, the sensor is not able to detect movement.

2/ 2-step dimming function:

After power on, the sensor automatically turns on light at 100% brightness. After 10sec, it dims the light to a low light level (set by stand-by dim level). During the initialization, the sensor is not able to detect movement.

11. Factory Setting

Detection area: 100%, Hold Time: 5S, Stand-by Period: 0S, Stand-by dim level: Disable, Daylight Sensor: HS

12. Cancel the sensor function

Continuously turn off/on the power supply for three times in 2s to cancel the sensor function, and the light stays on.

Turn the power off/on again and the sensor returns to the sensor mode.

13. Application Notice

- 1) The product dimming function needs to be equipped with an 1-10V dimming LED driver.
- 2) The sensor should be installed by a professional electrician. Please turn off the power before installing, wiring, changing the setting of the DIP switch.
- 3) The sensor mounted in a plastic, glass lampshade would reduce the sensitivity of the sensor. For every 3 mm increase in thickness, the sensitivity would reduce by 20%.
- 4) The sensing distance will be affected by the height of the sensor installation, the size of the object being detected, and the speed of movement.
- 5) Daylight the value is in a sunny environment with no shadows and ambient light diffuse reflection conditions. The values illumination detected by sensor may vary in different environment, at different times, in different seasons, and in different climates.
- 6) The parameters of the sensor may need to be reconfigured in different installation environments. Please refer to the following instructions or contact the manufacturer.
- 7) This sensor is for indoor use only. Outdoor use will affect the waterproof effect, wind and moving objects around would cause false triggering.
- 8) The distance between any inductive sensors should be greater than 3m.
- 9) When the sensor is installed in a metal illuminance, a metal reflective surface, or a narrow enclosed environment, the microwave will be reflected repeatedly and cause false triggering. Please reduce the sensitivity or contact the manufacturer for technical support.
- 10) Do not place the sensor close to high-density objects such as metal, glass, mixed-use walls, etc. The sensor may be triggered by mistake.
- 11) Please ensure that there are no moving signals around the sensor, such as fan, DC motor, sewer, air outlet, etc., the sensor may generate false triggers.