



greenlux
cost reduction LED lighting

Tempest Strip Series LED T8 Parking Fixture



Replaceable
LED Strip

- Replaces traditional T8 Fixture
- Smart Microwave Motion Sensor or Step Dimming 12V Motion Sensor for options
- 0-10V SAA Certified Driver
- Emergency Battery option Available
- Easy installation and maintenance
 - Diffuser permanently attached by 2 clips
 - 2 x 6mm terminal blocks, middle and ends
 - 2.5A wire connecting all two terminal blocks
 - Gear tray restraints for easy maintenance
 - Ceiling, wall or suspension mounting with optional mounting brackets
 - Multiple drill-out conduit entry points, middle and ends
- LED strip is easily replaceable to allow for easy maintenance
- High light output 120lm/W
- High quality LED Chipset SMD 2835
- Polycarbonate body and diffuser, vandal resistant
- Stainless steel clips, tamper resistant
- Applications include carparks, hallways, utility areas, food preparation areas, including outdoor locations

Specifications

| | |
|--------------------------------|--|
| Colour Range | 3000/4000/5000/6000k |
| Power Consumption | 20W/40W/50W/60W/80W |
| Input Voltage | 100-277V AC |
| CRI | 83 / 90 |
| IP Rating | IP66 |
| Product Dimensions (mm) | 618*116*74 (LxWxH) 1215*116*74 (LxWxH) 1515*116*74 (LxWxH) |
| Housing Materials | Polycarbonate Body & Lens / Aluminum Heat Sink |





greenlux
cost reduction LED lighting

Tempest Strip Series LED T8 Parking Fixture

Dimensions & Photometric

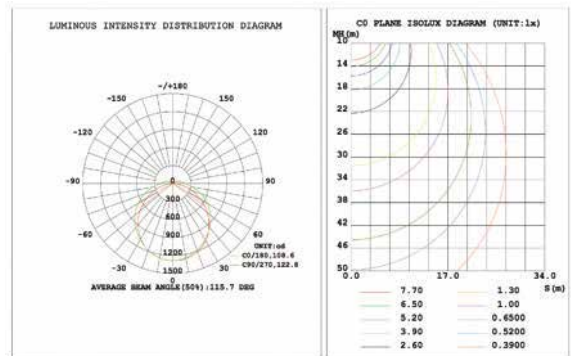
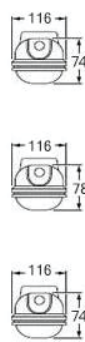
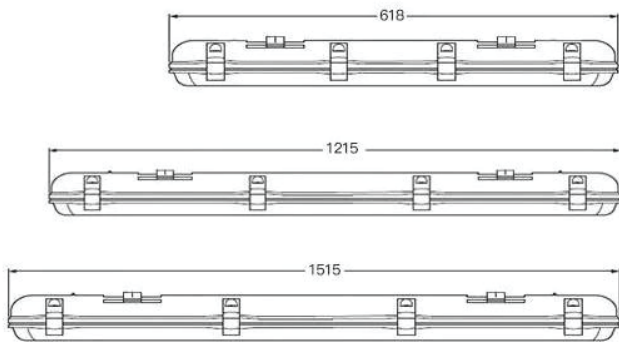

| Model No. | Wattage | Dimensions(mm) | Lumens Flux | CCT(K) |
|--------------|---------|----------------|---------------|------------------------------|
| GOTET-20W-2F | 20W | 618X116X74 | 2100lm/2600lm | |
| GOTET-40W-4F | 40W | 1215X116X74 | 4200lm/5200lm | |
| GOTET-60W-4F | 60W | 1215X116X74 | 7200lm | 3000 4000 5000 6000 |
| GOTET-50W-5F | 50W | 1515X116X74 | 5250lm/6500lm | |
| GOTET-60W-5F | 60W | 1515X116X74 | 6300lm/7800lm | |
| GOTET-80W-5F | 80W | 1515X116X74 | 9600lm | |

Tempest Strip Series LED T8 Parking Fixture

Emergency

| | |
|-------------------------------|-----------------------|
| Type | Self-test (Monthly) |
| Battery (Rechargeable) | 9.6V Ni-MH or Lithium |
| Emergency Standard | AS 2293 |
| Emergency Output | 30% nominal power |
| Emergency Duration | >90 Minutes |
| Charge Time | <12 Hours |

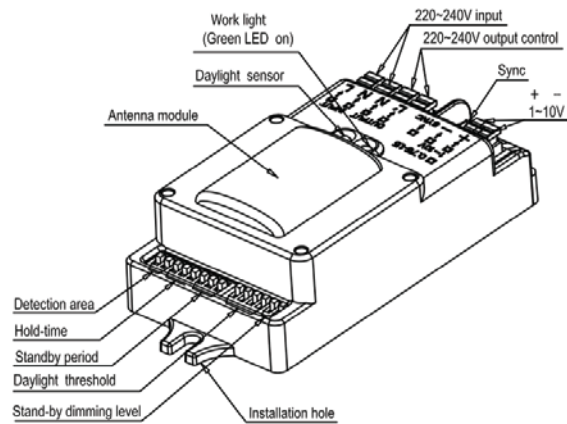

Microwave Motion Sensor

| | |
|-------------------------------|--|
| Operating Voltage | 120-277V AC, 50-60Hz |
| Rated Capacitive Load | 120V@400W; 220-240V@800W; 277V@1000W |
| HF System | 5.8 GHz +/- 75MHz, ISM wave band |
| Transmitting power | < 0.5mW |
| Power consumption | < 0.5W(standby), < 1W (operation) |
| Detection Zone | Max.(D x H): 16m x 15m |
| Detection Sensitivity | 10%/50%/75%/100% |
| Hold Time | 5s / 30s / 90s / 3min / 20min / 30 min |
| Daylight Sensor | 2 lux / 5 lux / 10 lux /25 lux / 50 lux /100 lux / Disable |
| Stand-by Period | 0s / 5s / 5min / 10min / 30min / 1 h / + ∞ |
| Stand-by-dimming Level | 10% / 20% /30% / 50% |
| Mounting Height | 15m Max |
| Motion Detection | 0.5~3m/s |
| Detection Angle | 150°(wall installation); 360°(ceiling installation) |
| Operating Temperature | -35°C~70°C |

Tempest Strip Series LED T8 Parking Fixture

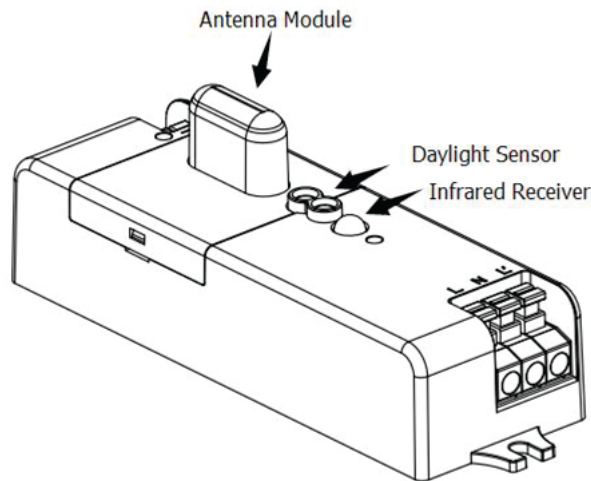

Step Dimming 12V Motion Sensor

| | |
|----------------------------|--|
| Operating Frequency | 5.8 GHz \pm 75 MHz, ISM Band. |
| Transmitting Power | 0.5mW Max. |
| Hold Time | 5s/30s/1min/3min/5min/10min/20min/30min |
| Stand-by DIM Level | 10%(1.4-1.6V), 20%(1.9-2.1V), 30%(2.9-3.1V), 50%(4.9-5.1V) |
| Stand-by Period | 0s/10s/1min/3min/5min/10min/30min/+ ∞ |
| Detection Area | 100%/75%/50%/25% |
| Daylight Sensor | 5lux/15lux/30lux/50lux/100lux/150lux/Disable |
| Detecting Radius | \geq 4m(mount height 3m, moving speed 0.3m/s) |
| Mounting Height | 6m Max |
| Detecting Angle | 150° |

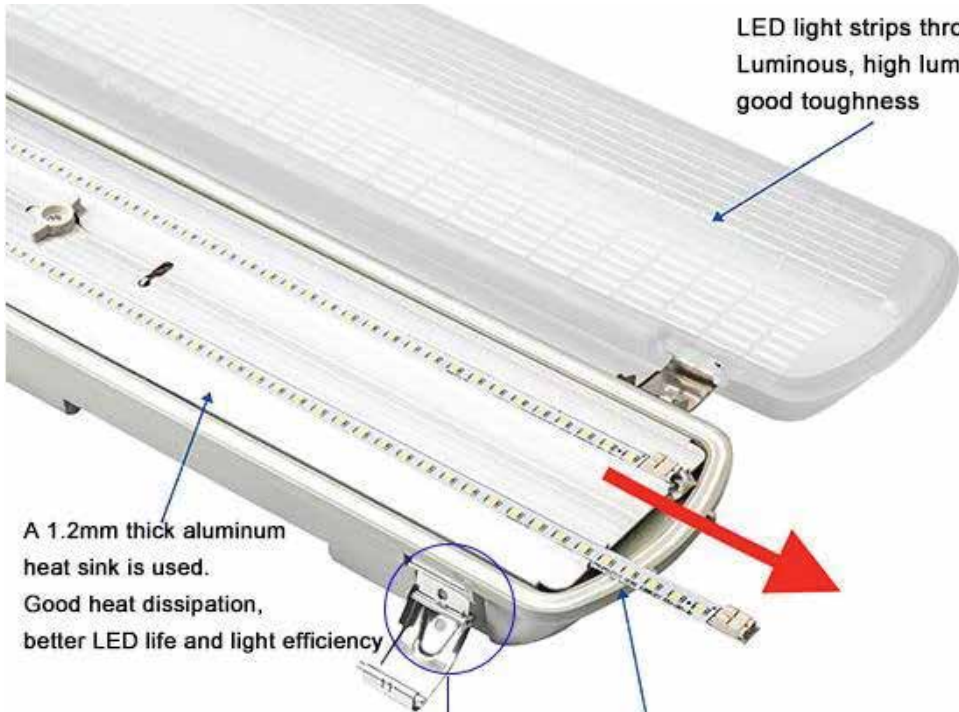

LED light strips through a single layer shade
Luminous, high luminous efficiency,
good toughness

A 1.2mm thick aluminum
heat sink is used.
Good heat dissipation,
better LED life and light efficiency

Each lamp has a quick terminal block
Can extract and replace



Snap screw
Quick installation,
destruction,
anti-disassembly