

HBL ST 01

LED Linear High Bay

Features

- Cold rolled steel housing
- Aluminum heatsink
- Poly carbonate lens
- Replaceable LED strips
- Isolated LED driver
- 120° beam angle
- 100-277V, 50-60Hz
- CRI > 83
- Easy maintenance
- 5 years warranty



Options

- 4FT/5FT
- CCT 3000K/4000K/5000K/6000K
- Dimming Options: Triac/0-10V/Dali
- Microwave Motion Sensor
- Emergency Battery Backup

Specifications

Power Consumption	40W ~ 240W
Lumens	110lm/W
PF	>0.95
LED Typer	2835 SMD

Dimensions & Materials

Product Dimensions (mm)	4Ft	1225 * 175 * 73	(L * W * H)
	5Ft	1511 * 175 * 73	(L * W * H)

Housing Colour White / Black / Grey

Housing Material Aluminum Housing + PC Cover

Installation Surface Mounted
Suspended

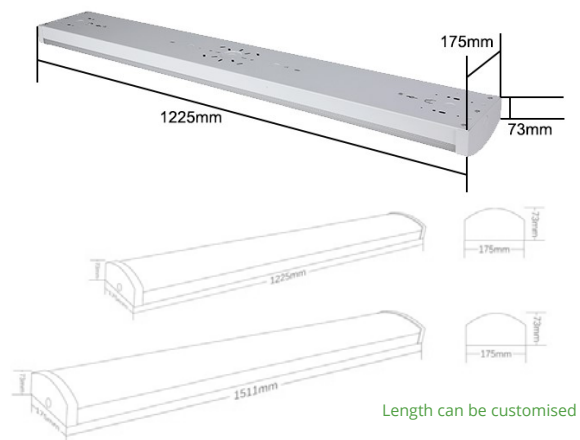

SAA

IES

IP40

CE

RoHs

LM80

5 Yrs
Warranty

HBL ST 01

LED Linear High Bay

Details

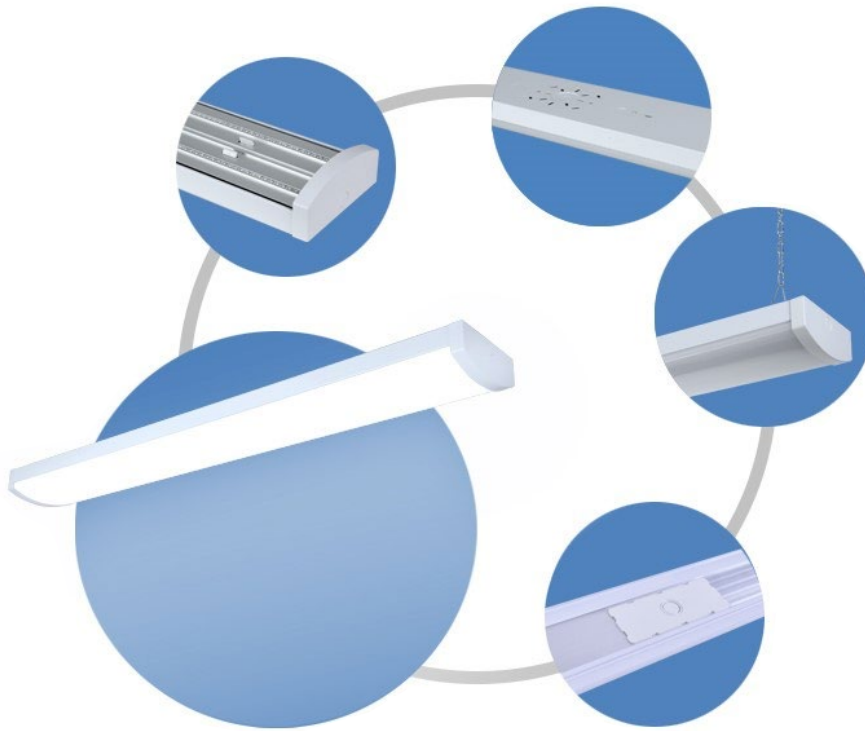

Model	Wattage	Dimensions (mm) L * W * H	Lumens
GOHBL-40W-4F-ST01	40W	1225 x 175 x 73	4200lm / 5200lm
GOHBL-60W-4F-ST01	60W	1225 x 175 x 73	6300lm / 7800lm
GOHBL-80W-4F-ST01	80W	1225 x 175 x 73	9600lm
GOHBL-90W-4F-ST01	90W	1225 x 175 x 73	11700lm
GOHBL-120W-4F-ST01	120W	1225 x 175 x 73	14400lm
GOHBL-50W-5F-ST01	50W	1511 x 175 x 73	5250lm / 6500lm
GOHBL-60W-5F-ST01	60W	1511 x 175 x 73	6300lm / 7800lm
GOHBL-100W-5F-ST01	100W	1511 x 175 x 73	12000lm
GOHBL-120W-5F-ST01	120W	1511 x 175 x 73	14400lm
GOHBL-90W-5F-ST01	90W	1511x 175 x 73	9450lm / 11700lm
GOHBL-150W-5F-ST01	150W	1511x 175 x 73	18000lm
GOHBL-180W-5F-ST01	180W	1511x 175 x 73	21600lm

HBL ST 01

LED Linear High Bay

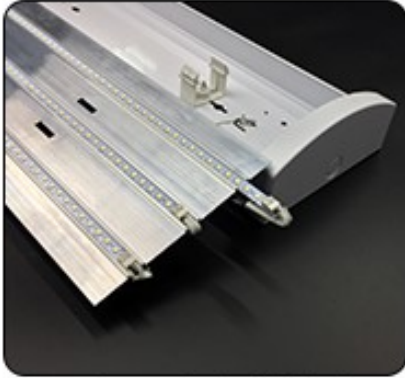

Replaceable light bar



Built-in aluminum heat sink

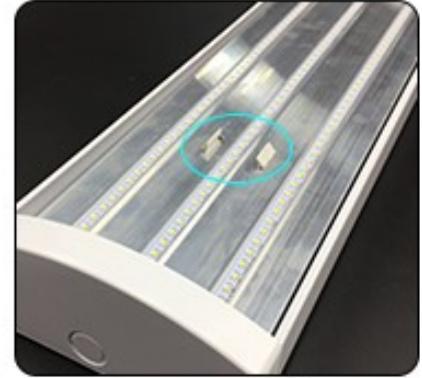

Snap-on fixing

Optional Additions



Microwave Motion Sensor



0-10V Dimming



Emergency Battery



347V 480V