

# HBL ST 02

## LED Linear High Bay

### Features

- Cold rolled steel housing
- Aluminum heatsink
- Poly carbonate lens
- Replaceable LED strips
- Isolated LED driver
- 120° beam angle
- 100-277V, 50-60Hz
- CRI > 83
- Easy maintenance
- 5 years warranty



### Options

- 4FT/5FT/8FT
- CCT 3000K/4000K/5000K/6500K
- Dimming Options: Triac/0-10V/Dali
- Microwave Motion Sensor
- Emergency Battery Backup

### Specifications

<b>Power Consumption</b>	40W ~ 240W
<b>Lumens</b>	110lm/W
<b>PF</b>	>0.95
<b>LED Typer</b>	2835 SMD

### Dimensions & Materials

<b>Product Dimensions (mm)</b>	4Ft	1195 * 250 * 55	(L * W * H)
	5Ft	1480 * 250 * 55	(L * W * H)
	8ft	2375 * 250 * 55	(L * W * H)

<b>Housing Colour</b>	White / Black / Grey
<b>Housing Material</b>	Aluminum Housing + PC Cover
<b>Installation</b>	Surface Mounted Suspended

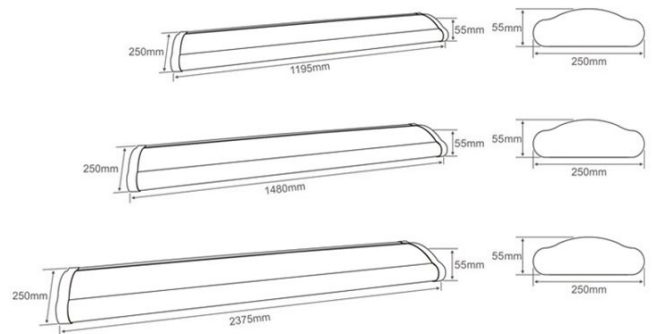

# HBL ST 02

## LED Linear High Bay

### Details

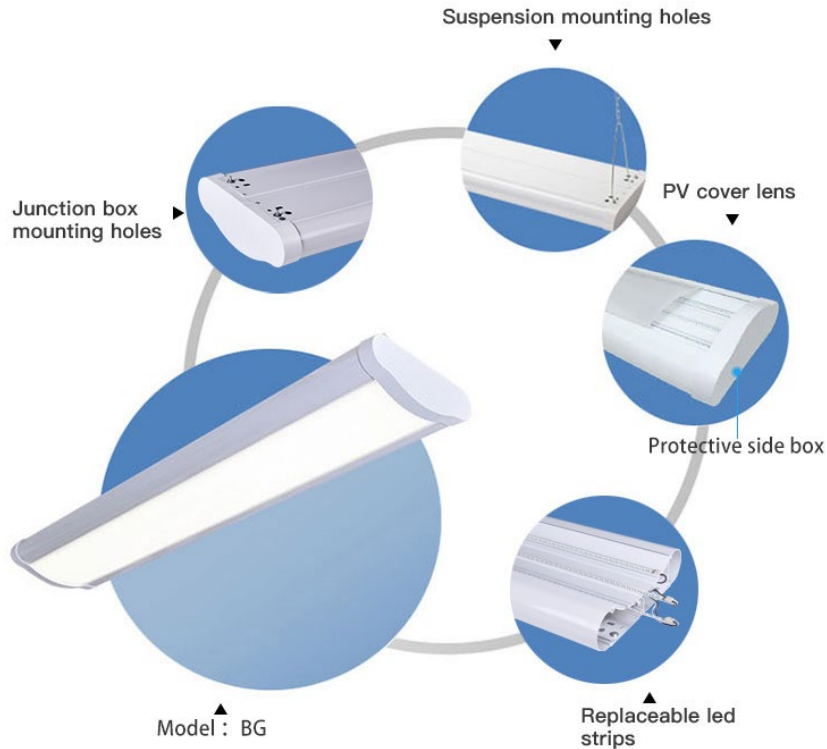

Model	Wattage	Dimensions (mm) L * W * H	Lumens
GOHBL-40W-4F-ST02	40W	1195 x 250 x 55	4200lm / 5200lm
GOHBL-60W-4F-ST02	60W	1195 x 250 x 55	6300lm / 7800lm
GOHBL-80W-4F-ST02	80W	1195 x 250 x 55	8400lm / 10400lm
GOHBL-120W-4F-ST02	120W	1195 x 250 x 55	14400lm
GOHBL-160W-4F-ST02	160W	1195 x 250 x 55	19200lm
GOHBL-200W-4F-ST02	200W	1195 x 250 x 55	24000lm
GOHBL-50W-5F-ST02	50W	1480 x 250 x 55	5250lm / 6500lm
GOHBL-60W-5F-ST02	60W	1480 x 250 x 55	6300lm / 7800lm
GOHBL-100W-5F-ST02	100W	1480 x 250 x 55	10500lm / 13000lm
GOHBL-120W-5F-ST02	120W	1480 x 250 x 55	12600lm / 15600lm
GOHBL-200W-5F-ST02	200W	1480 x 250 x 55	24000lm
GOHBL-240W-5F-ST02	240W	1480 x 250 x 55	28800lm
GOHBL-80W-8F-ST02	80W	2375 x 250 x 55	8400lm / 10400lm
GOHBL-120W-8F-ST02	120W	2375 x 250 x 55	12600lm / 15600lm
GOHBL-180W-8F-ST02	180W	2375 x 250 x 55	21600lm
GOHBL-240W-8F-ST02	240W	2375 x 250 x 55	28800lm

# HBL ST 02

## LED Linear High Bay



### Easy maintenance

Press the terminal to replace the led strips when it broken, saving much cost



### A strong drop

The line is hidden with the interior, safe and anti-breaking

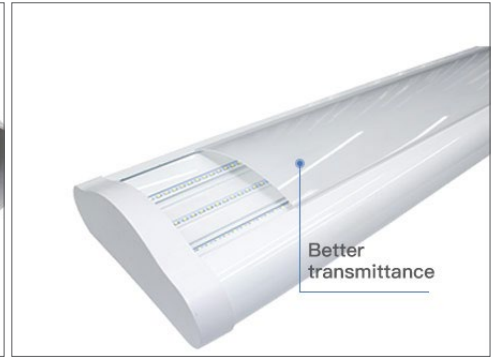

### Superior lumen effect

Epistar SMD 2835 LED  
Poly carbonate lens  
high lumen performance

## Optional Additions



Microwave Motion Sensor



0-10V Dimming



Emergency Battery



347V 480V