

# SL G1 Series

## LED Street Light

*Commercial & Industrial Lighting*

Remote Control

IP66 | IK08 | 140lm/W

# LED STREET LIGHT LED SHOEBOX LIGHT

### Application

Highway | Parking lot | Walkways | Roadways | Campuses & other public areas



**140**  
lm/W



30W / 50W / 60W / 80W / 100W / 120W / 150W / 180W / 200W / 240W

### Optional:

1. Class I or Class II
2. 140lm/W or 160lm/W

#### Self-clean

Smooth body would greatly diminish dust accumulation and bird droppings heap up.

#### Buckle Design

Buckle for fixing heat sink could be opened without tools. Which keeps the installation and maintenance secure and convenient.

#### Housing Material

High strength and high quality ADC12 die casting aluminum body. Die casting aluminum housing with reliable powder coating for harsh outdoor environments. Dustproof, waterproof.

#### Multiple Installation

Two installation methods, no need to change any accessory

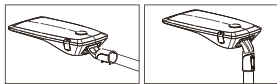

Dia: 64mm  
Suitable for 50-62mm

#### Clear glass + Anti-UV PC Lens

Adopt LUMILEDS original LED light source, provide types of optional beam angle, control the light distribution rationally, ensure street surface with ideal brightness and uniformity.

#### Power-off Protection

Power would automatically be off once the fixture body opened.



# SL G1 Series

## LED Street Light

*Commercial & Industrial Lighting*

Remote Control

### Better Solutions for LED Street Light

-  IP66 water-proof
-  AC100-277V 50/60Hz
-  Easy Installation
-  140lm/W

Operation Temp.: -40°C~+50°C    Storage Temp.: -40°C~+80°C



### Options

#### Power

MEAN WELL DRIVER  
SOSEN DRIVER

#### CCT

3000K  
4000K  
5000K  
5700K

#### Beam Angle

Type II-S (151\*81°)  
Type II-M (147\*72°)  
Type III-M (156\*71°)  
Type IV-M (100\*65°)  
Type V (150°)

### Application

- Tunnel light
- Residential area
- Sports field
- Landscape
- Parking lot
- Architectural decorative lighting
- Garden
- Roads

### Specifications

Model	Power	Luminous Efficacy	LEDs	CRI	Weight	Lens
GBSL-30W-G1	30W	140lm/W	3030	> 80	5.0kg	Type II-S / II-M / III-M / IV-M / V
GBSL-50W-G1	50W				5.0kg	
GBSL-60W-G1	60W				5.0kg	
GBSL-80W-G1	80W				5.0kg	
GBSL-100W-G1	100W				7.0kg	
GBSL-120W-G1	120W				7.0kg	
GBSL-150W-G1	150W				7.0kg	
GBSL-180W-G1	180W				8.5kg	
GBSL-200W-G1	200W				8.5kg	
GBSL-240W-G1	240W				8.5kg	

### Model Options



30W / 50W / 60W / 80W



100W / 120W / 150W



180W / 200W / 240W

# SL G1 Series

## LED Street Light

*Commercial & Industrial Lighting*

### Remote Control

### Dimensions (mm)

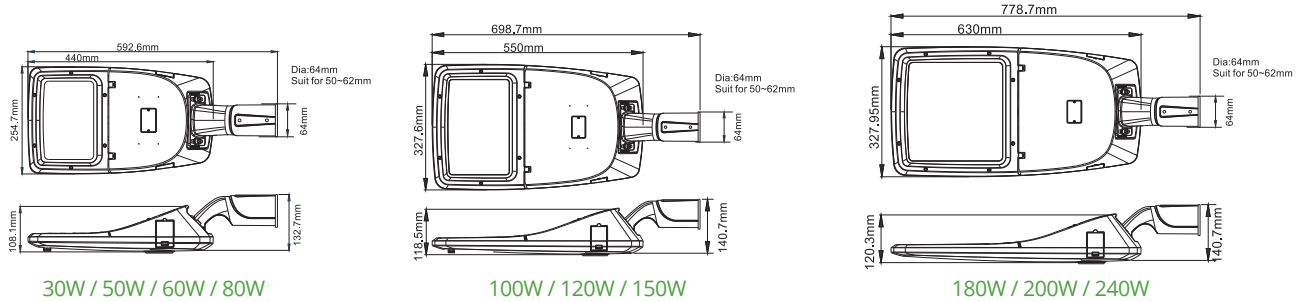

### Photometry

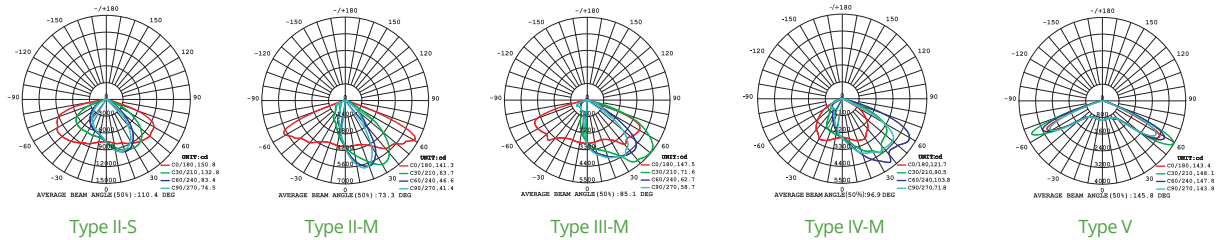

### Sensor Optional



<b>Control optional</b>	BR-SEN-16A1-REMOTE Extra Remote Control Options for U3/U4 Sensor

<b>Others optional</b>	1. SPD 10KV IP65 (Standard) 2. SPD 20KV IP65

### Installation and Use (P1 Slip Fitter)

